



MPEQ-1 User Manual Version 1.2

1. INTRODUCTION.....	2
2. SAFETY/POWERING UP	4
3. RACK MOUNTING.....	7
4. AUDIO CONNECTIONS.....	8
5. FRONT PANEL CONTROLS.....	9
6. THE EQUALIZER	
The Filters.....	13
The 4 Parametric Bands.....	16
Series Vs. Parallel.....	20
Notch Mode.....	22
7. PRESET SETTINGS	25
API.....	26
Neve	27
SSL	28
Pultec	28
8. SPECIFICATIONS.....	29
9. USER DOCUMENTS	30
EQ WTF Guide.....	31, 32
Recall Sheets.....	33, 34

VERSION 1.1 NEW INFORMATION ON PAGES 17, 20, 21, 24-34

1. INTRODUCTION

Congratulations! You are the proud owner of the UTA MPEQ-1: one of the most powerful and musical Class A equalizers ever built as well as a wonderfully flexible, beautiful sounding Class A Mic Preamp/DI. The MPEQ-1 packs a huge amount of Class A audio power into a single rack unit. Whether you are tracking or mixing, we are confident you will find the MPEQ-1 to be an indispensable tool in the music making process.

To get up and running right away with your MPEQ-1, skip to Chapters 2 (Powering Up), 3 (Rack Mounting), and 5 (Front Panel Controls). The most vital information about the proper installation of the MPEQ-1 in this manual is in Chapter 3 (Rack Mounting). The rest of the manual contains more detailed information that is not essential for understanding the units basic functionality.

The development of the MPEQ-1 began with the process of building a custom console. The Equalizer was the single most important element of the design. I needed an EQ that would do everything all of my other EQs did. It needed to have the musicality of a classic Neve or EMI but the flexibility of a GML or Orban. Larry Jasper and I worked for years refining the design that ended up in our consoles and is now available in the MPEQ-1. The equalizer in the MPEQ-1 unit is identical to the Equalizer in the channel strips of the UTA consoles.

What's so special about the EQ? It is the only Parametric Equalizer that utilizes Class A amplifiers for EVERY active gain stage in the EQ. Most "Class A" EQs will use a Class A gain stage only for the final summing stage. The UTA EQ uses Class A gain stages for all of the integrator stages, all buffering stages, summing stages... Everything. This offers a level of musicality and clarity that is not available from any other EQ. The EQ also incorporates features that have never before been available in a hardware EQ unit – let alone one that is Class A. The ability to blend between peak and shelf shape EQs, as well as being able to reverse the phase of a portion of the frequency spectrum, are features that just simply have not been available before.

The features took years of experimentation to develop. The first version of the EQ became unstable with certain combinations of settings. It would literally turn into a synthesizer and blast +28 dB of a distorted square wave out the output. We thought we were sunk and that I would not be able to have the flexibility I wanted while keeping the circuit stable. Patience and persistence yielded the answer. It forced us to change to a totally different approach for tackling the subtractive EQ (when you turn down a frequency). This different approach had an unintended benefit. We realized that this approach allowed us to add the "Notch" mode and the Phase manipulation mode.

The original design was simply going to have a peak mode and shelf mode. The challenge was to figure out what the character or slope of the shelf mode would be. We set up the original prototype with a trim pot to be able to adjust the slope of the shelf shape. As soon as I had a chance to play with this control, I decided it should exist on the front panel... And thus the "Shape" control was born! Each band can blend from a peak shape - to a modern shelf shape - to a vintage shelf shape - and everything in between. The UTA EQ can literally emulate the shape or slope of any shelf EQ ever created, and it can do an endless number moves that no other EQ has ever been able to do.

After I had been using the EQ for months and months in the first UTA console, I started to realize that there were certain shapes involving combinations of bands that were being difficult to create. This was a result of the unique type of “cutting” the EQ does combined with the parallel architecture of the EQ circuit. When I had multiple bands of EQ cutting close to each other, the interaction between the bands was much more dramatic than I was expecting. We decided to make another change to the circuit and have the EQ bands be ordered both in Series and in Parallel. This ended up adding a whole other aspect of flexibility to the EQ. You can decide if you want a more parallel type interaction or series type interaction depending on which bands you choose to use. All of the EQs in my consoles were modified to incorporate this new approach.

These significant discoveries and changes are only a few of the notable moments of endless hours experimenting, testing, and real world use that has helped refine what we feel is the best equalizer ever built.

The mic preamp has gone through similar exhaustive testing, recording, and listening tests to end up with the best possible combination of components and features. The goal with the mic preamp was to have something that would could give me the vintage musicality I was used to with a Neve or EMI pre, but also have the option of running the mic pre cleaner when needed. We came up with a mic pre wherein the user can bypass either or both of the transformers. It offers some useful tonal flexibility that now makes the UTA pre my first pick for almost every recording situation. We also added a low impedance mode by changing the strapping of the input transformer that performs extraordinarily well with passive ribbon mics. It is now the only mic pre I use with all of my ribbon mics.

2. SAFETY/POWERING UP

SAFETY INSTRUCTIONS



WARNING: To reduce the risk of fire or electric shock, do not expose this product to rain or moisture.



CAUTION: RISK OF ELECTRIC SHOCK. DO NOT OPEN. There are no user serviceable parts inside the product. Refer servicing to qualified service personnel.

In order to ensure safe operation of the device, follow these guidelines:

1. Read the instruction manual in its entirety before operating the equipment. Retain the manual for future reference.
2. Observe all safety precautions, warnings and instructions noted in this manual.
3. Always unplug this device from the wall socket before cleaning. Use only dry cloth. Do not use aerosols or solvents.
4. Keep this device away from sources of water such as pools, bathtubs and sinks, and do not expose it to rain or splashes of water. Do not place objects filled with fluid on the device.
5. Vents are provided for heat dissipation on the sides and the rear of the device. Maintain at least 2" (5cm) space around these vents to provide sufficient ventilation.
6. Keep the device away from sources of heat and open flame such as heaters, radiators, stoves, lit candles, etc..
7. Make sure the power cord is intact before plugging it into the device. Do not use cords with visible damage to the insulation or connectors.
8. This device is equipped with a safety feature that requires the use of a three-pin grounding power plug. Do not defeat the safety purpose of the grounding plug. If the provided plug does not fit your outlet, consult an electrician to replace your obsolete power outlet.
9. Use only accessories listed in this manual or otherwise specified by the manufacturer.
10. Do not install this product on carts or other moving objects.
11. When the device is in use, route the power cord in such a way that will prevent it from being stepped on, tripped on, pinched or damaged.

12. Do not use this device with wall or ceiling mounts not specified by the manufacturer.
13. To completely disconnect the device from the AC Mains, disconnect the power cord from the AC receptacle. For additional protection, unplug the device during electrical storms, or when not used for long periods of time.
14. No user serviceable parts inside. Refer servicing to qualified personnel. If the unit was exposed to liquid, excessive heat or fire, or sustained mechanical damage of any kind, do not attempt to operate it. Disconnect the unit from the wall outlet and consult qualified service personnel.

INSTRUCTIONS FOR 220-240VAC OPERATION

1. Before proceeding, disconnect the power cord from the AC inlet.
2. This device is provided with a power cord for North American 110-120VAC operation. For operation in other locations and/or from other voltage sources, use the correct type of power cord for your area and voltage source.
3. This device is provided with T 0.4A AC Mains fuses installed for 110-120VAC operation, and includes T 0.2A accessory fuses for 220-240VAC operation packed separately. Open the fuse drawer on the AC receptacle on the rear of the device and replace the T 0.4A fuse with the T 0.2A accessory fuse.
4. In the fuse drawer, change the AC Mains switch from the 110V position to the 240V position.
5. Assure that the fuse drawer is secured closed before attaching the power cord.

INSTRUCTIONS POUR 220-240VAC FONCTIONNEMENT

1. Avant de commencer, débranchez le cordon d'alimentation de la prise secteur.
2. Cet appareil est fourni avec un cordon d'alimentation pour l'Amérique du Nord 110-120VAC 60 Hz. Pour une utilisation dans d'autres endroits et / ou d'autres sources de tension, utiliser le bon type de cordon d'alimentation de votre région et source de tension.
3. Cet appareil est fourni avec T 0.4A AC Mains fusibles installés pour une opération de 110 120 V ca, et comprend T 0.2A accessoires fusibles pour un fonctionnement 220-240VAC emballés séparément. Ouvrez le tiroir du fusible sur la prise secteur à l'arrière de l'appareil et remplacer le fusible de 0.4A T avec l'accessoire fusible T 0.2A.
4. Dans le tiroir de fusible, changer les secteur CA passer de la position 110V à la position 240V.
5. Assurez-vous que le tiroir à fusibles est fixé fermé avant de fixer le cordon d'alimentation.

POWERING UP

Before you connect the AC power cable, check to make sure the AC operating voltage on the unit is set to properly match the voltage of your AC outlets. The options are 110V (appropriate for 110V - 120V range) or 240V (appropriate for 220V - 240V range). The operating voltage of the MPEQ-1 can be changed by removing the small tray in the power entry module. Simply flip around the small PCB inside the tray so the correct voltage is showing in the window when the tray is re-inserted in the power entry module. When changing the MPEQ-1 to a different operating voltage, you must also change to the appropriate fuse value to be sure it is either properly protected, or won't immediately blow the fuse (see *Picture 1 or 2* for appropriate fuse values). **PLUGGING THE MPEQ-1 INTO A 220V- 240V OUTLET WHEN SET FOR 110V OPERATION WILL LIKELY RESULT IN DAMAGE TO THE POWER SUPPLY OF THE UNIT AND REQUIRE SENDING IT BACK TO UTA FOR REPAIR!!!**

Once you have confirmed the operating voltage is set correctly, make sure the power switch is in the "OFF" or "DOWN" position. Plug the supplied IEC AC power cable into the AC power receptacle on the back of the unit. Plug the other end into an appropriate grounded AC outlet. You are now ready to power up the unit. Simply push the power switch on the front panel to the "ON" or "UP" position. When the MPEQ-1 is powered you will see the VU meter jump around for a couple of seconds. This is normal. The illumination of the VU backlight LED is the indication that the MPEQ-1 is powered up and ready for use.

The MPEQ-1 is protected by a "slow blow" or time delay fuse. The fuse can be found mounted in the removable tray (see *Picture 3*). There is also a small compartment that holds a spare fuse. The spare fuse is a T0.4A fuse for 110V operation. If the MPEQ-1 blows a fuse, it is best to first try to determine what caused the fuse to fail before installing the spare. Once the cause for failure has been resolved, install the spare fuse and you are ready to go!

Picture 1

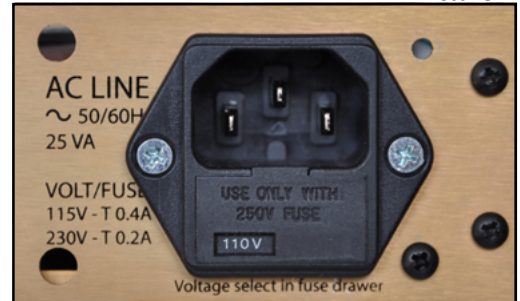

Picture 1 shows the MPEQ-1 set in the 110V mode. This will work for voltages from 110V - 120V

Picture 2

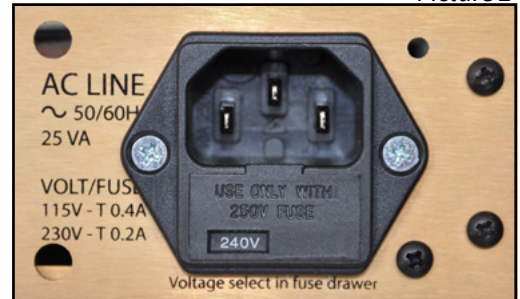

Picture 2 shows the MPEQ-1 set in the 240V mode. This will work for voltages from 220V - 240V

Picture 3



Picture 3 shows the fuse tray and the hidden spare fuse housing

Picture 4

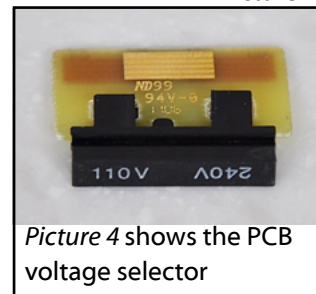

Picture 4 shows the PCB voltage selector

3. RACK MOUNTING

As you have seen repeatedly in this manual, the MPEQ-1 is a Class A device. Class A circuitry unavoidably generates heat. How one chooses to rack-mount these devices can have a significant affect on the ambient temperature inside the enclosure. We have done everything we can (short of using a fan) to improve the thermal performance and have put them through “worst case” rack mounting scenarios to make sure that they will perform reliably under those conditions. We just want to make people aware of how the various rack mounting options will affect the thermal performance.

THE WORST POSSIBLE WAY TO MOUNT MULTIPLE MPEQ-1S IN A RACK, IS TO STACK THEM ONE ON TOP OF EACH OTHER. When three MPEQ-1s are stacked on top of each other in a rack, the one in the middle will maintain an average internal ambient temperature of about 120°F (49°C). If you stack 6 of them, the middle units can get up to 130°F (54°C), 8 of them can get over 140°F (60°C). The MPEQ-1 is protected by thermistors. When the units get in the 140°F (60°C) range, the thermistors will start to shut down the various DC voltages. **THIS IS VERY IMPORTANT!! IF THE LIGHT IN THE VU METER TURNS OFF AND/OR THE MPEQ-1 STOPS PASSING AUDIO WHILE THE POWER SWITCH IS TURNED ON, THAT MEANS THAT A THERMISTOR HAS TRIPPED BECAUSE THE UNIT IS RUNNING TOO HOT!!** Simply turn off the MPEQ-1, change the rack mounting situation such that it allows the unit to run cooler and then power it back up. Everything should be fine. The thermistors will reset themselves after the unit cools down and if the new rack mounting arrangement keeps things cool enough, it will not happen again. The temperature at which components inside the unit would start to actually burn up is around 220°F (105°C). We are a long ways away from that, but here is the catch. The closer you get to that temperature, the shorter life span the internal components will have.

WE STRONGLY RECOMMEND LEAVING A GAP BETWEEN EACH MPEQ-1 MOUNTED IN A RACK. If you mount the MPEQ-1 with even just a 1/3 of a rack space between each unit, the average internal ambient temperature will be 105°F - 115°F (41°C- 46°C). An MPEQ-1 sitting by itself in a rack will maintain an average internal temperature of about 100°F (38°C). Here is the crazy thing, if you mount an MPEQ-1 vertically, the average internal temperature drops as low as 80°F(27°C)!!! It turns out that the standard the world has chosen for orienting rack mount equipment (horizontally) SUCKS for thermal dissipation. If you have the option of mounting the MPEQ-1 vertically it is unquestionably the best way to do it (It is also best for pretty much all rack mount gear).

At the end of the day, keeping the internal temperature of the MPEQ-1 lower will most likely give it a longer life span. How much longer? Well, we are not really sure. We expect the MPEQ-1 to function without any need for service for around 15 years. Will stacking these on top of each other in a rack shave off 1, 2 or 3 years from that expectation? We just won't know for sure for about 10-15 years from now. We recommend mounting the units in a way that will keep them as cool as possible, whenever possible.

4. AUDIO CONNECTIONS

Fig. 1

REAR AUDIO INPUTS/OUTPUTS

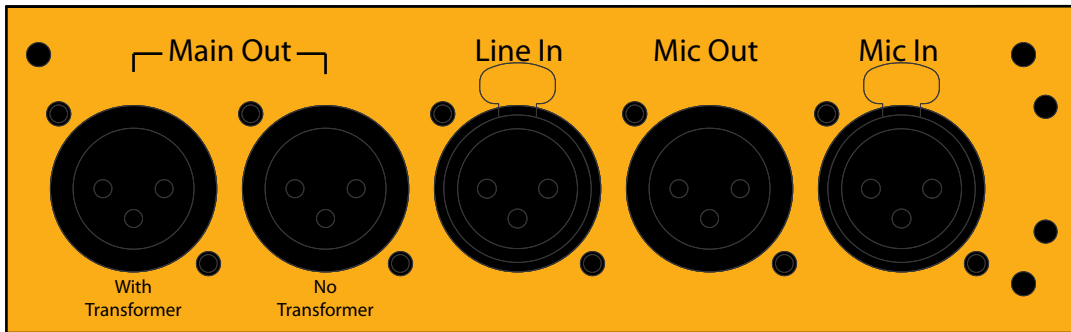

MIC IN (REAR) - This is one of 2 input connectors available for getting signal into the mic preamp. The rear mic input is convenient to use if the MPEQ-1 is rack mounted and wired to a patch bay. The rear mic input connector will automatically be disconnected as soon as an XLR or 1/4" cable is plugged into the front Mic/DI input jack.

MIC OUT - This male XLR connector gives you access to the unbalanced output signal of the mic pre before it goes to the EQ circuit. This allows you to split the MPEQ-1 into separate mic preamp and EQ units. When using the Mic Preamp output, you will be bypassing the "Trim" control, the Phase Reverse and the option of using the output transformer.

LINE IN - This female XLR connector allows you to connect a line level signal directly to the input of the Equalizer.

MAIN OUT (NO TRANSFORMER) - This male XLR connector allows you to connect to the unbalanced, transformerless output from the Equalizer.

MAIN OUT (WITH TRANSFORMER) - This male XLR connector allows you to connect to the transformer balanced output from the Equalizer.

FRONT AUDIO INPUTS

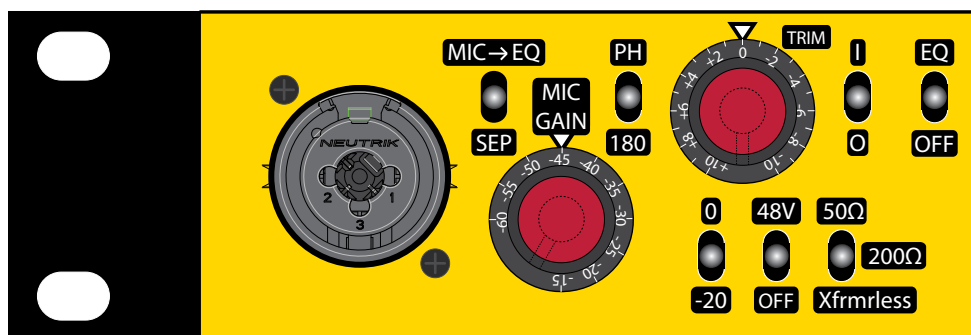

MIC/DI IN (FRONT) - This Neutrik combo jack allows you to plug either a male XLR or a 1/4" instrument connector directly into the front of the unit. When a male XLR connector is plugged in, the combo jack automatically switches to only allow signal from the front "MIC IN" jack to go to the mic preamp. When a 1/4" jack is plugged in the combo jack automatically switches the circuitry to function as a Class A DI and also disconnects the rear "MIC IN" jack.

5. FRONT PANEL CONTROLS

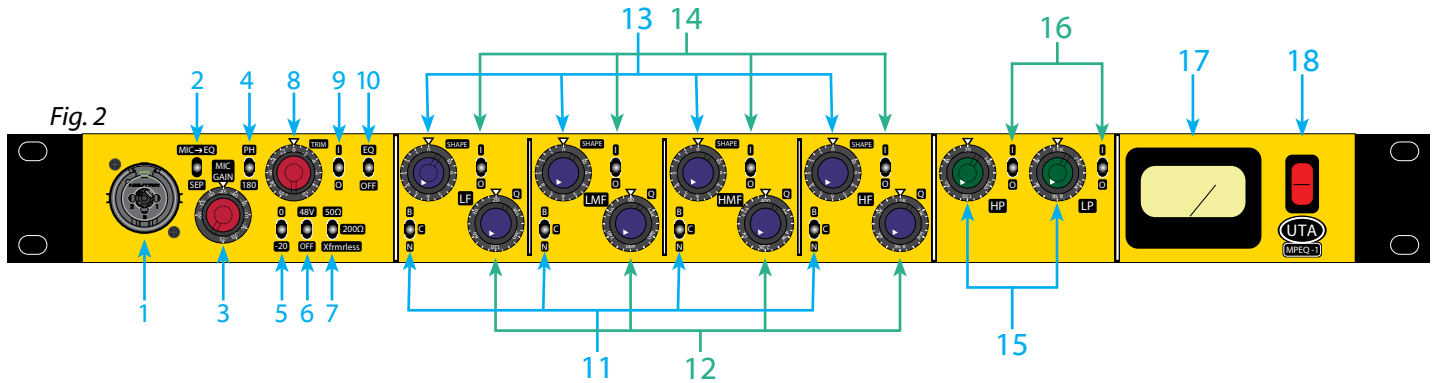

DESCRIPTION OF FRONT PANEL CONTROLS

1. FRONT MIC AND DI INPUT - This combo jack input allows you to plug either a microphone cable or 1/4" instrument cable directly into the front of the unit. Plugging a mic cable into the front mic input automatically disables the rear mic input. Plugging in a 1/4" instrument cable allows you to use the MPEQ-1 as a DI. When a 1/4" cable is plugged in, both the front and rear mic inputs are disabled.

2. MIC->EQ vs. SEP - When this toggle switch is in the up or "MIC->EQ" position, the signal from the mic pre will be sent directly to the input of the EQ. When in this mode, the "Line In" input on the rear is disabled. When this toggle switch is in the down or "SEP" (meaning "separate") position, The mic pre and equalizer can be used as two separate units. The mic pre and DI can be used individually via the front or rear mic inputs with the rear "Mic Out" jack. The EQ can be used individually via the "Line In" jack on the rear panel with one of the 2 "Main Out" jacks. NOTE: The output transformer is ONLY available on the main output. The "Mic Out" jack is always transformerless.

3. MIC GAIN - This rotary switch allows you to adjust the amount of gain on the mic pre from -10dB to -60dB in 5dB steps.

4. PHASE - This toggle switch allows you to reverse the polarity of the signal coming into the Equalizer "Line In". Phase is normal when in the up or "PH" position. Phase is reversed when in the down or "180" position. When in the "MIC->EQ" mode, it allows you to reverse phase on the mic pre signal. NOTE: You will not be able to reverse the phase of the mic pre signal if it is being used separate from the equalizer.

5. PAD - This toggle switch engages the passive -20dB pad before the mic pre. There is no padding when the switch is in the up or "0" position. -20dB of padding is added when the switch is in the down or "-20" position.

6. 48V - This toggle switch turns on or off the 48V "phantom power". Turn this on when using microphones that require "phantom power" to function. Turning the 48V "phantom power" on or off can cause a very loud low frequency "thump" to come out of the mic pre. Make sure you turn down your monitors or headphones when changing the 48V setting. **NOTE: Some ribbon microphones can be damaged by "phantom power". It is always best to turn off the phantom power before plugging in any type of passive ribbon mic.**

7. 50Ω/200Ω/Xfrmless - This 3 position toggle switch selects the transformer mode for the input of mic pre-amp.

50Ω - In the "UP" or "50Ω" position, the input transformer is configured for a low impedance high gain input. This setting works especially well for passive ribbon microphones. You will typically get an added 3 or 4 dB of gain with no additional amplifier noise. It also has sonic benefits as well. We have found the ribbon mics to sound clearer, more balanced, and solid in this mode.

200Ω - This mode is best if you want to add input transformer coloration while using either dynamic or condenser type microphones.

Xfrmless - This mode removes the input transformer from the input of the mic preamp. It will give you the same input impedance and gain as the "200Ω" mode. This offers a unique opportunity to hear a transformerless Class A mic preamp. It is a stunningly pristine sound and is ideal for any recording that needs the highest degree of clarity and detail. **NOTE: switching to or from the "Xfrmless" mode will cause a loud low frequency thump (similar to turning the 48V on/off). Be sure you have your speakers or headphones turned down whenever switching to or from the transformerless mode.**

8. TRIM - The "TRIM" is a constantly variable control that allows you to boost or cut the signal +/-10dB. This control is specifically on the input of the Equalizer circuit. It will ONLY affect the level of the mic pre when you are in the "MIC->EQ" mode. The mic pre has no fine trim of level when used individually. In addition to simply having a fine adjust of the level, there are two other applications of the fine trim that can be very helpful:

- 1) The fine trim can be used to turn down the level from the mic pre going into the EQ. This allows you to drive the mic pre more without over driving the input of your recording device. The UTA Class A mic preamp sounds great when you overdrive it!
- 2) The fine trim gain stage has a unique configuration that causes the noise from this gain stage to decrease when the gain is turned up. You can use it to add 10dB of gain to the mic preamp (a combined total of +70dB) without adding any additional amplifier noise.

9. TRIM I/O - This toggle switch turns on or off the variable trim control. When the toggle switch is in the "Up" or "I" position, the variable trim control is active allowing you to boost or cut the equalizer input signal 10dB. When the switch is in the "down" or "O" position, the variable trim control is deactivated and the equalizer input gain is unity.

10. EQ/OFF - This toggle switch turns on or off the entire EQ circuit. When the toggle switch is in the "Up" or "EQ" position, The EQ circuit is added to the signal path. When the toggle switch is in the "Down" or "OFF" position the entire EQ circuit is bypassed.

11. B/C/N - This three position toggle switch selects the mode for the gain adjust on an individual parametric band of the EQ.

B - In the "Up" or "B" position, the gain control for that band will boost whatever frequency/shape is selected up to 15dB.

C - In the "Middle" or "C" position, the gain control for that band will cut whatever frequency/shape is selected as much as 15dB.

N - In the "Down" or "N" position, the gain control for that band will allow you to either notch out a frequency or reverse the phase of a particular frequency. *(For more information on the notch mode see pg. 22 in The Equalizer section)*

12. FREQUENCY/Q CONTROL (PARAMETRIC BAND) - This dual concentric potentiometer allows you to select the frequency being adjusted and the "Q" or "Bandwidth" of the adjustment being made.

The Upper Knob controls the "Q" or "Bandwidth". In the fully counter-clockwise position, you get the widest "Q" of .3. As the knob is turned clockwise the "Q" will get more narrow. In the fully clockwise position you get the most narrow "Q" of 10.

The Lower Knob controls the frequency selection. The frequency gets lower as the knob is turned counter-clockwise and conversely, will get higher as the knob is turned clockwise.

13. GAIN/SHAPE - This dual concentric potentiometer controls both the amount of gain adjust and the shape of the adjustment.

The Upper Knob controls the shape. In the fully counter-clockwise position, the EQ band will boost or cut a "bell" or "peak" type shape. As the knob is turned clockwise, the shape progressively turns into a shelf. The 12 o'clock position achieves a conventional shelf shape. Past the 12 o'clock position, you can change the slope of the shelf.

The Lower Knob controls the amount of gain adjust. When the B/C/N toggle switch (*see item 11 in section 4*) is in the "B" or "C" modes you can boost or cut 15 dB of the selected frequency. (*Certain shelf/Q combinations will allow as much as 30 dB of boost or cut*).

When the B/C/N toggle switch is in the "N" position, the gain control will allow you to either notch the selected frequency or reverse the phase of the selected frequency. To notch the selected frequency, set the gain control to "5". To reverse phase of the selected frequency, set the gain control to "10". (*See section 6 "The Equalizer" for more information on the Notch mode*).

14. EQ BAND I/O - This toggle switch turns on or off an individual band of the equalizer. When the toggle switch is in the "up" or "I" position, the EQ band will be engaged. When the toggle switch is in the "down" or "O" position, the EQ band circuitry will be bypassed.

15. FREQUENCY/Q (FILTERS) - These dual concentric potentiometers allow you to adjust the frequency and the "Q" of the HP/LP filters.

The Upper Knob controls the "Q". In the fully counter-clockwise position, the filter will have the most gradual roll off. As the knob is turned clockwise the "Q" will get progressively steeper. At the 12 o'clock position, you will get the steepest possible roll off (about 12dB per octave) without boosting the selected frequency. As the "Q" control is turned clockwise past the 12 O'clock position, The frequency selected will begin to be boosted. In the fully clockwise position there will be 10dB of boost at the selected frequency and the slope of the roll off averages out to around 18dB per octave.

The Lower Knob controls the frequency selection. The frequency gets lower as the knob is turned counter-clockwise and conversely, will get higher as the knob is turned clockwise. On the skirt of the knob, you will see a scale showing the range of frequency corresponding to a particular setting.

16. FILTER I/O - This toggle switch turns on or off an individual filter band. When the toggle switch is in the "Up" or "I" position, the filter band is active. When the switch is in the "down" or "O" position, the filter band will be bypassed.

17. VU METER - This is a VU meter that will show the level present at the input of the EQ circuit. When the MPEQ-1 is in the "MIC->EQ" mode, the VU will show the level of the signal coming from the Mic Preamp. In the "SEP" mode the VU will show the level of signal connected to the "Line In". In either case, the VU will reflect any adjustments made with the "Trim" control. The VU does NOT show the resulting level caused by any EQ cutting or boosting.

(We felt it was best to have the VU function the way a VU does on a console channel strip, Where the VU specifically shows the level at the input of the channel strip and does not show any level changes caused by EQ adjustments. The level resulting from EQ changes can be seen with the metering of the recording device being used. If you would prefer to have the VU show the final output level including any level changes caused by EQ adjustments, there is a relatively easy modification that can make that happen.)

18. POWER SWITCH - This switch turns on or off the power for the MPEQ-1. In the up position, the power is turned on. In the down position, the MPEQ-1 will be powered off. The LED lighting in the VU can be used as an indication whether or not the MPEQ-1 is on or off.

6. THE EQUALIZER

In this section we will take a very in depth look at the functions of the UTA EQ. If you want a quick over view of the EQ functions, see *Section 4 (Front Panel Controls)*.

There are far too many possible combinations of settings and curves that can be created by the MPEQ-1 to be able to show graphs of all of them. We will only be showing graphs of settings with a frequency selection of 1.5 kHz and in either LP or High Shelf modes. The HP, Low Shelf, or "Cut" counter parts will look like a mirror image version of what is shown in these graphs (**see pg. 17 for important new information about the mirroring of EQ shapes**).

Similar to many modern equalizers, the MPEQ-1 has both "High Pass" and "Low Pass" filters. The terms "High Pass" and "Low Pass" can be a bit confusing. "High Pass Filter" is referring to the REMOVAL of LOW frequencies below a selected frequency, or in a more technical sense, the filter is allowing the higher frequencies to "Pass" through the circuit while blocking or filtering the lower frequencies. Conversely, "Low Pass Filter" refers to the REMOVAL of HIGH frequencies while letting the frequencies below a selected frequency "Pass" through the circuit.

The thing that is unique about the LP/HP filters on the UTA EQ is the addition of an active "Q" control. This "Q" control allows you to change the slope of the roll off, as well as being able to actually create a boost or resonance at the frequency selected. It is important to understand that an active "Q" control is different than stacking filters to create steeper roll offs. The filters in the circuit are always 12 dB/octave. The "Q" control is changing how aggressively the filter is applied. When the "Q" is in the fully counter-clockwise position, the filter will ease into the 12 dB/octave roll-off.

Fig. 3

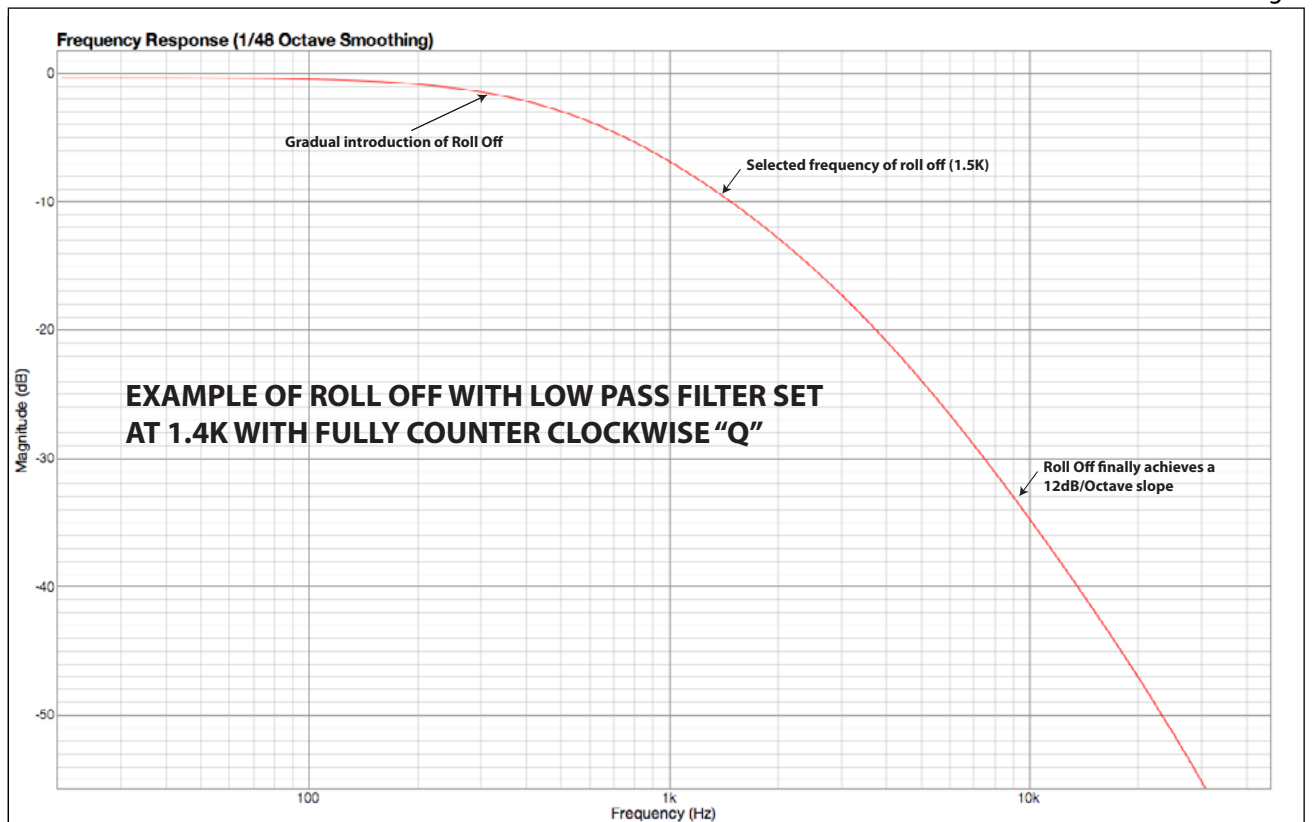

You can clearly see the gradual introduction of roll off much lower than the frequency selected. This setting is great when you want to gently roll off high or low frequencies in a way that sounds very natural. The gradual non-linear slope minimizes phasing anomalies and almost eliminates any resonance or "ringing" introduced by the filter. Also notice that there is a significant amount of roll off at the frequency selected. The frequency is set at 1.5 kHz and the roll off is already almost 10 dB down at that frequency. The lower "Q" settings will cause a greater amount of filtering because the filtering starts before the selected frequency.

Fig. 4

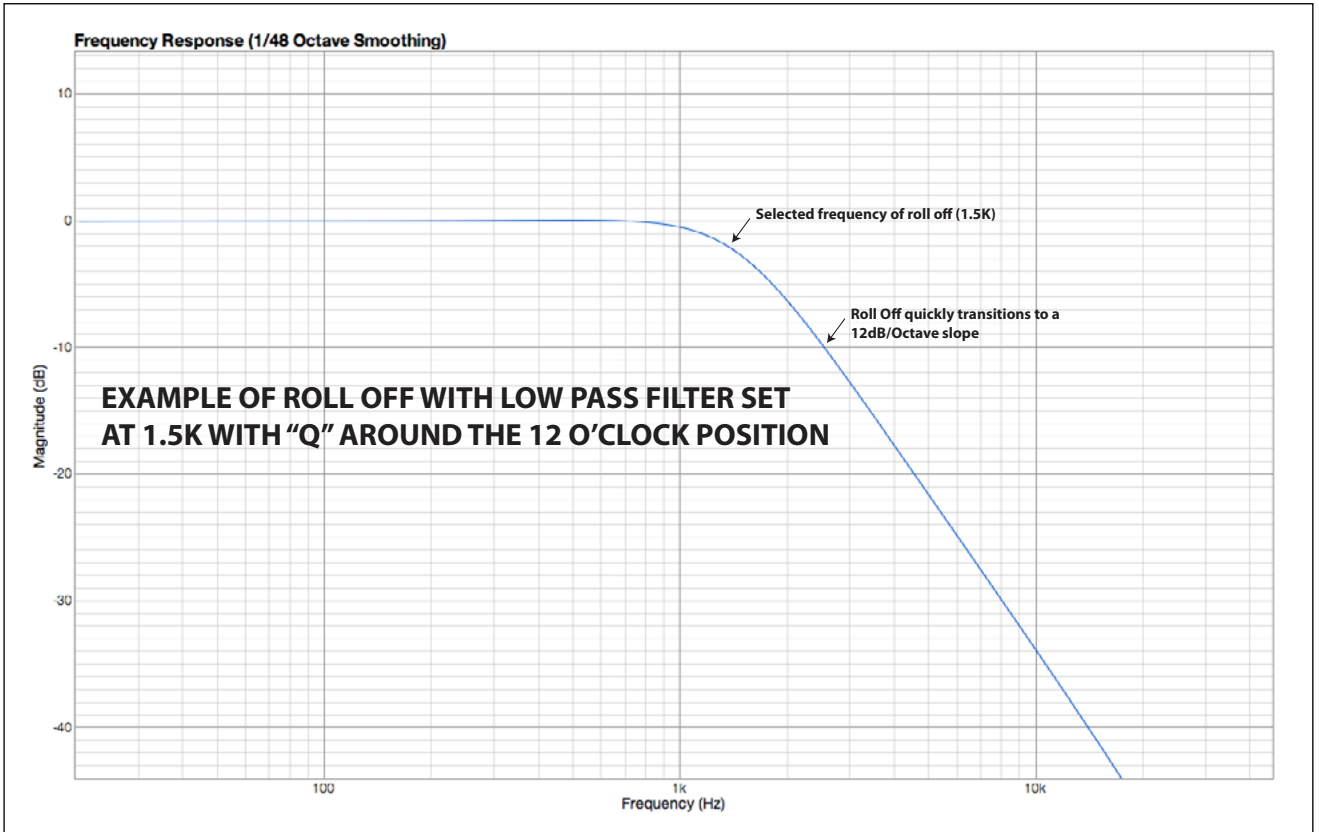

Fig. 4 illustrates how increasing the "Q" setting doesn't actually change the dB/octave value, but changes how quickly the roll off transitions into the 12 dB/octave roll off. The roll off initiates much closer to the selected frequency and quickly achieves a linear 12 dB/octave slope. This sounds much more similar to a conventional 12 dB/octave filter.

Fig. 5

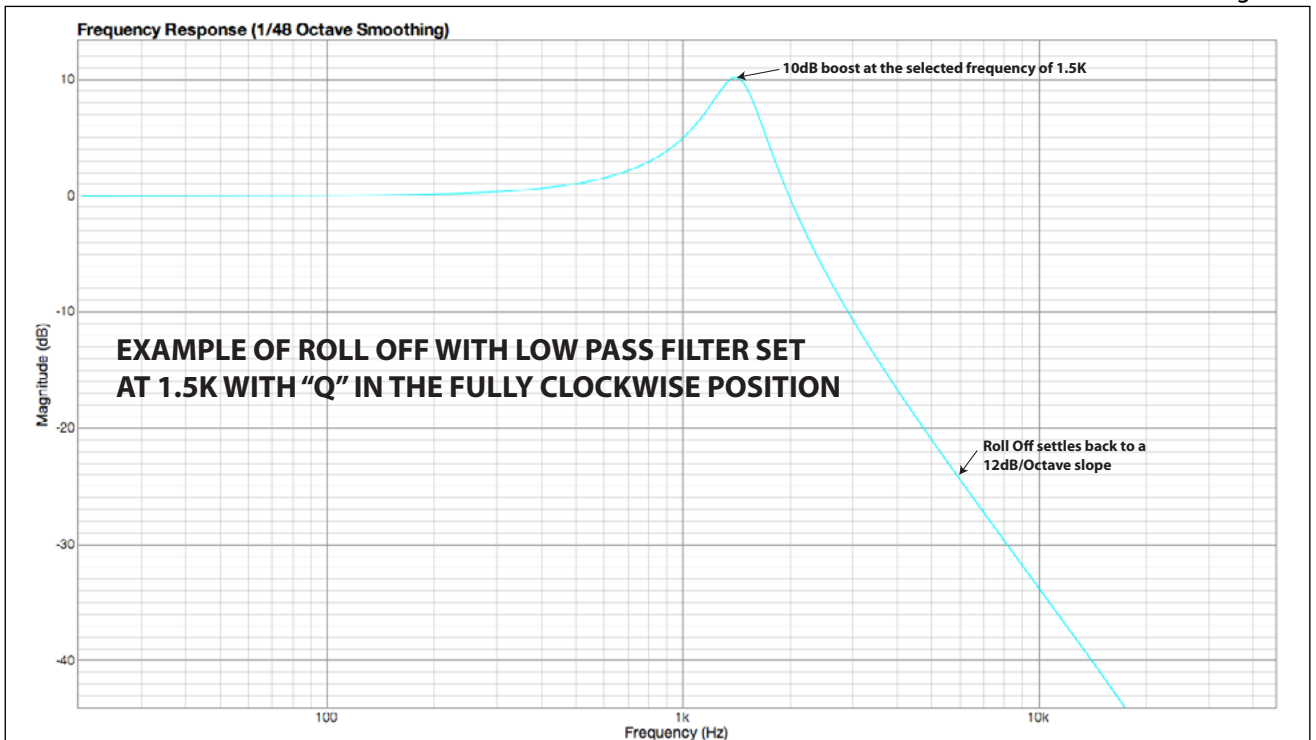

Fig. 5 illustrates the boost or resonance created with the higher “Q” settings. These higher “Q” settings can be great for creating filtering effects. You will really hear the ringing of the filter. You can create very effected “telephone” type lo-fi effects, or use it to do more musical, natural sounding filters as well. One of my favorite applications is with the low end -Using the high pass filter to boost low end is a very punchy sound; It can help focus the low end of an instrument to emphasize the natural resonance of the frequency range it is occupying.

It is really effective for kick drums; It removes any sub frequencies below the punchy part of the drums sound and focuses all of the energy in a place that will cut through a mix better without eating up headroom.

I also really like it for guitar. Many times, guitars will have rumbling noise below the range of notes that are actually being played. I have found with conventional High Pass Filters, the sound would get too thin when I rolled off at the point of the lowest note being played. With the “Q” control on the MPEQ-1 High Pass Filter, I can roll off at the lowest frequency, then restore the natural body to the sound by adding a boost or resonance at the lowest frequency that the instrument is playing.

Fig. 6

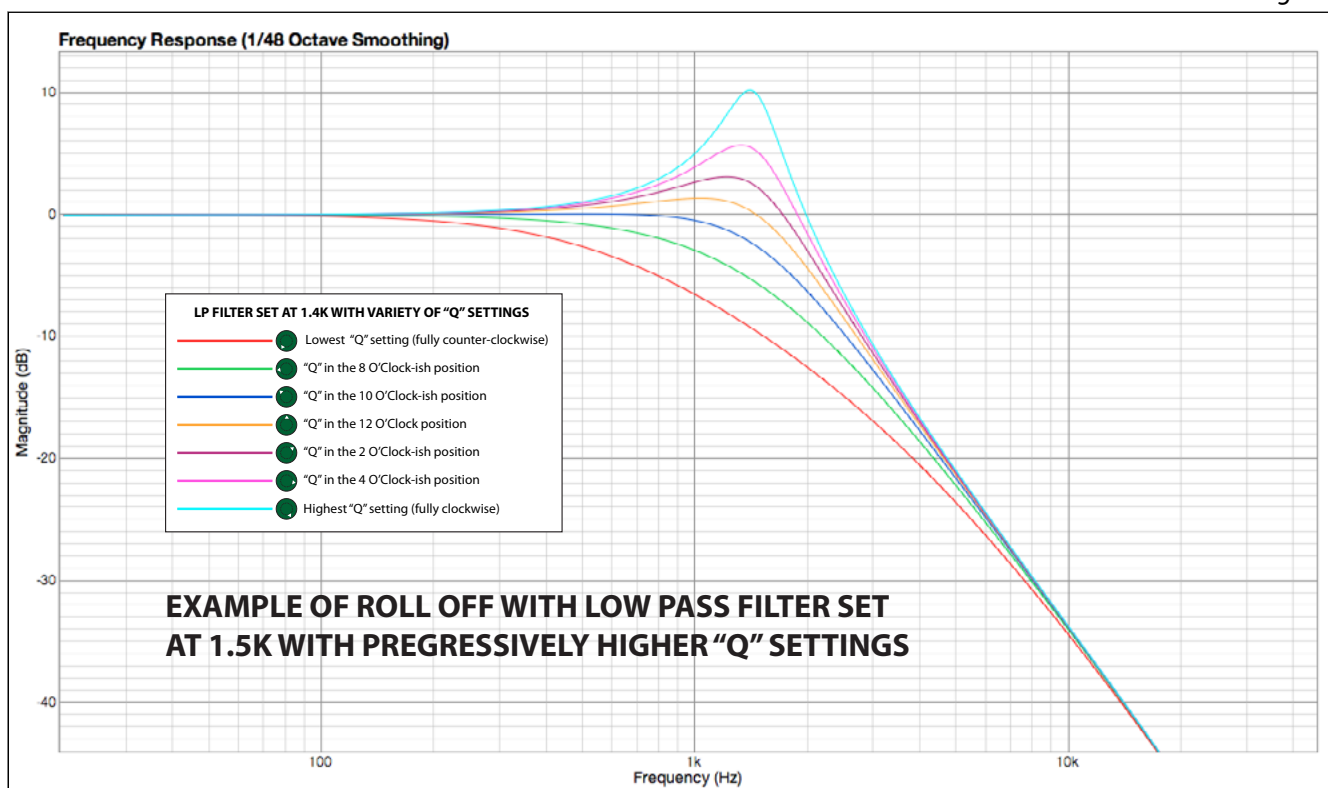

Fig. 6 allows you to better see how the slope and peaking develop as the “Q” control goes from the fully counter-clockwise position to the fully clockwise position.

THE 4 PARAMETRIC BANDS

The 4 parametric bands have 2 configurations. The HF and HMF bands can blend between a peak shape and a “High Shelf”. The LMF and LF bands can blend between a peak shape and a “Low Shelf”. The bands are also broken into two parallel groups that are then in series. Each band can be set to boost, cut, notch or manipulate phase. All of these variables combined create a staggering amount of flexibility and control over the shapes and curves the equalizer is capable of generating. We will try to cover as many of these combinations as possible.

THE “SHAPE” CONTROL

The shape control is blending between a peak or bell type shape and a shelf shape. When the knob is all the way counter-clockwise, it is a peak or bell shape. As the knob is turned clockwise, it turns progressively more into a shelf shape. In Fig. 7, you see how the peak or bell shape gradually transforms into a conventional shelf shape as you turn the shape control from the fully counter-clockwise position to the 12 o’clock position. Notice the HF band graphics that will show the exact setting combinations used to create each curve.

Fig. 7

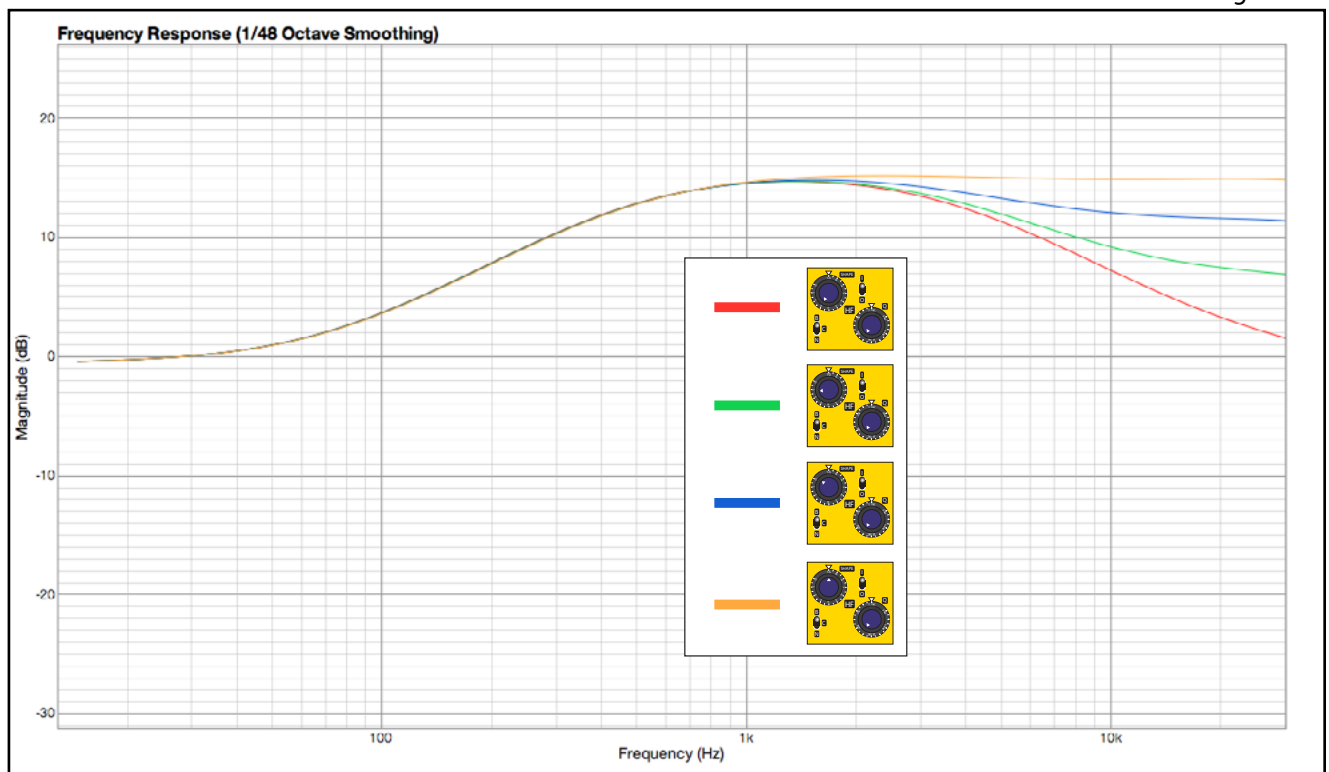

The green curve is a good example of how you can open up the top end a little when you’re doing a mid range boost. The yellow curve shows a conventional shelf shape where the boost starts to rise below the frequency selected, reaches its maximum amount of boost at the frequency selected and then stays up above the frequency selected.

In Fig. 8, you can see what happens as you continue to turn the shape control past the 12 o'clock position. This is the range of the shape control where you can actually change the slope and the contour of the shelf, allowing you to emulate the curve of pretty much any analog shelf EQ ever made.

Fig. 8

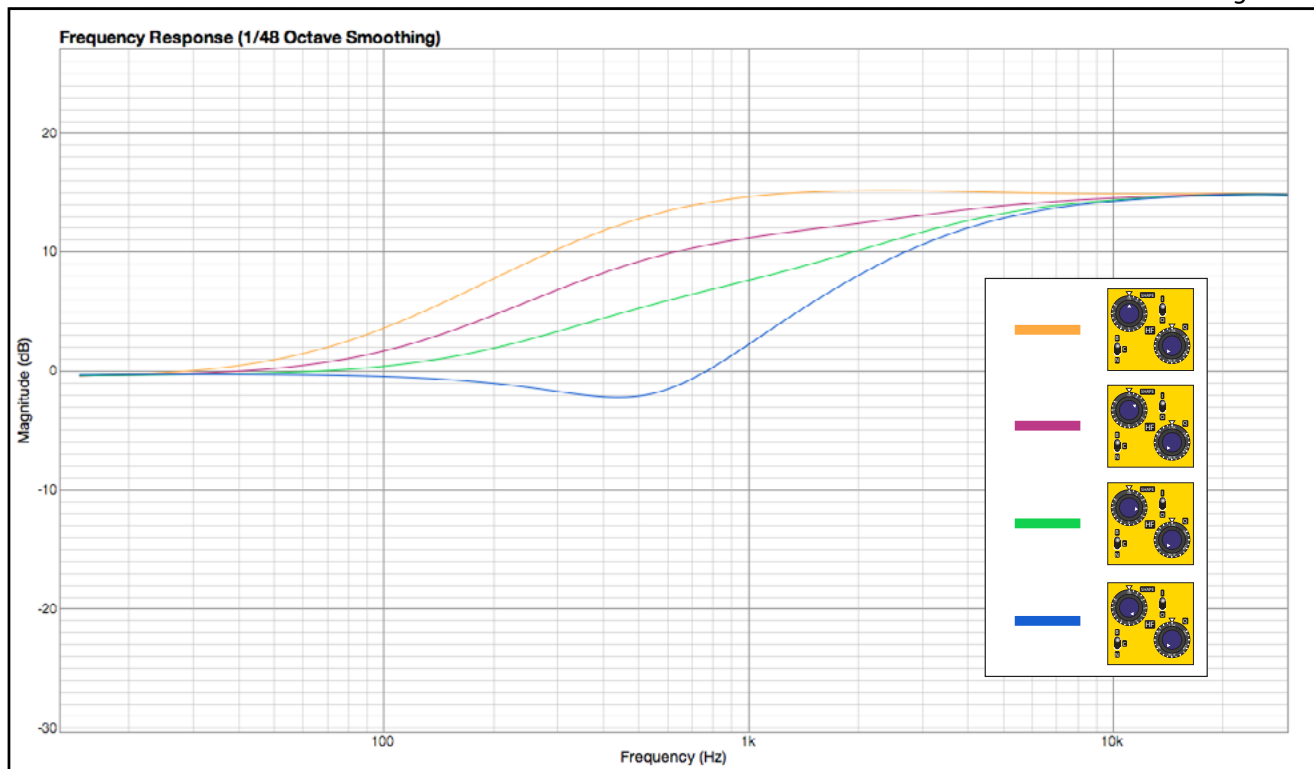

The green curve is a really useful shape because of the very linear, gradual rise of the boost. This minimizes phase anomalies and sounds extraordinarily natural. Use this shape if you want a sound to be brighter without really sounding EQed. The blue curve is an example of a more "classic" type shelf shape with an under shoot and the beginning of the slope. This curve is reminiscent of those on old 80 series Neve EQs. It is also important to note that, as the shape control goes past the 12 o'clock position, the frequency range being boosted will seem to get higher. The frequency selection is not actually changing, it is just the slope of the boost emphasizing the higher frequencies.

In the process of creating the presets for this manual, I discovered a behavior of the UTA EQ that I think is important for people to be aware of. Most of the shapes created with the EQ will mirror closely when switching from boost to cut, however there is an exception. When you move the shape control past the 12 o'clock position, a higher "Q" setting is needed to generate the same shape when cutting. The more the shape control is increased past the 12 o'clock position, the more you need to increase the "Q" to have the same shape when cutting. For example, to mirror the yellow plot shown above while cutting, you would leave the "Q" control fully counter clockwise. To have a mirror of the blue plot shown above, you have to increase the "Q" shown here:

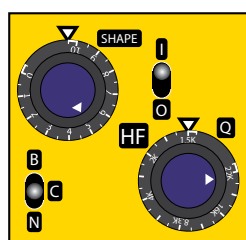

Cut "Q" difference

In Fig. 9 we will look at what happens when you start to combine the “Q” control with a shelf shape.

Fig. 9

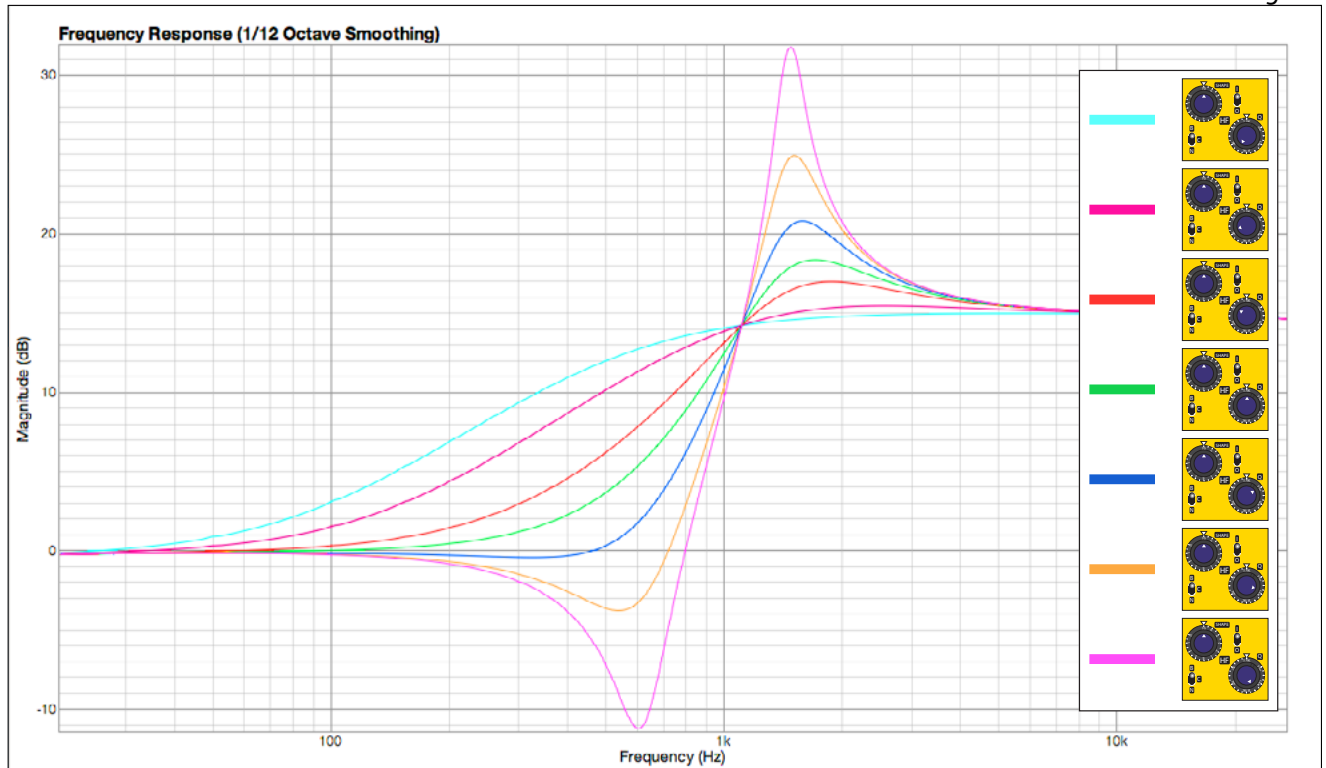

The curves in this graph show what happens when you progressively increase the Q (starting fully counter-clockwise and turning the knob clockwise) of a conventional shelf shape. You can see how a peak starts to develop on top of the initial shelf shape as the rise of the shelf gets steeper. Once you get past the 12 o'clock position, an undershoot starts to develop (an undershoot is the dip right before the rise in the curve). This combination of the shelf shape with the Q control can achieve a huge amount of boost. Notice that when the Q control is fully clockwise, there is more than 30 dB of boost happening at the selected frequency. **BE CAREFUL!!! BOOSTING 30 dB OF CERTAIN FREQUENCIES WHEN YOUR SPEAKERS ARE TURNED UP LOUD CAN RESULT IN SPEAKER AND/OR EAR DAMAGE.**

What is most useful about these combinations of shelf and Q is that you can achieve curves that would normally take 3 bands of an equalizer. Moreover, when these more complex curves are created with a single filter, there is an inherent musicality to it. It minimizes the compounding of phasing anomalies you get when creating a curve like this with multiple bands. The end result sounds more natural to the original sound.

I like using these combinations to move the energy in a sound from one area of the frequency spectrum to another in a more organic fashion. For example, if I have a bass guitar that needs to sound deeper, I can (with one band) boost frequencies below 100 Hz and simultaneously be reducing some of the frequencies just above 100 Hz. The bass just sounds deeper without really sounding EQed. In the high end frequencies, it is really great for adding a pointed ring to a shelf boost that will give the instrument a more identifiable character. This slight ringing can help it stand out from other elements in the mix.

In Fig.10 We will look at the range of widths available by adjusting the Q control with the shape control in the peak or fully counter-clockwise position.

Fig. 10

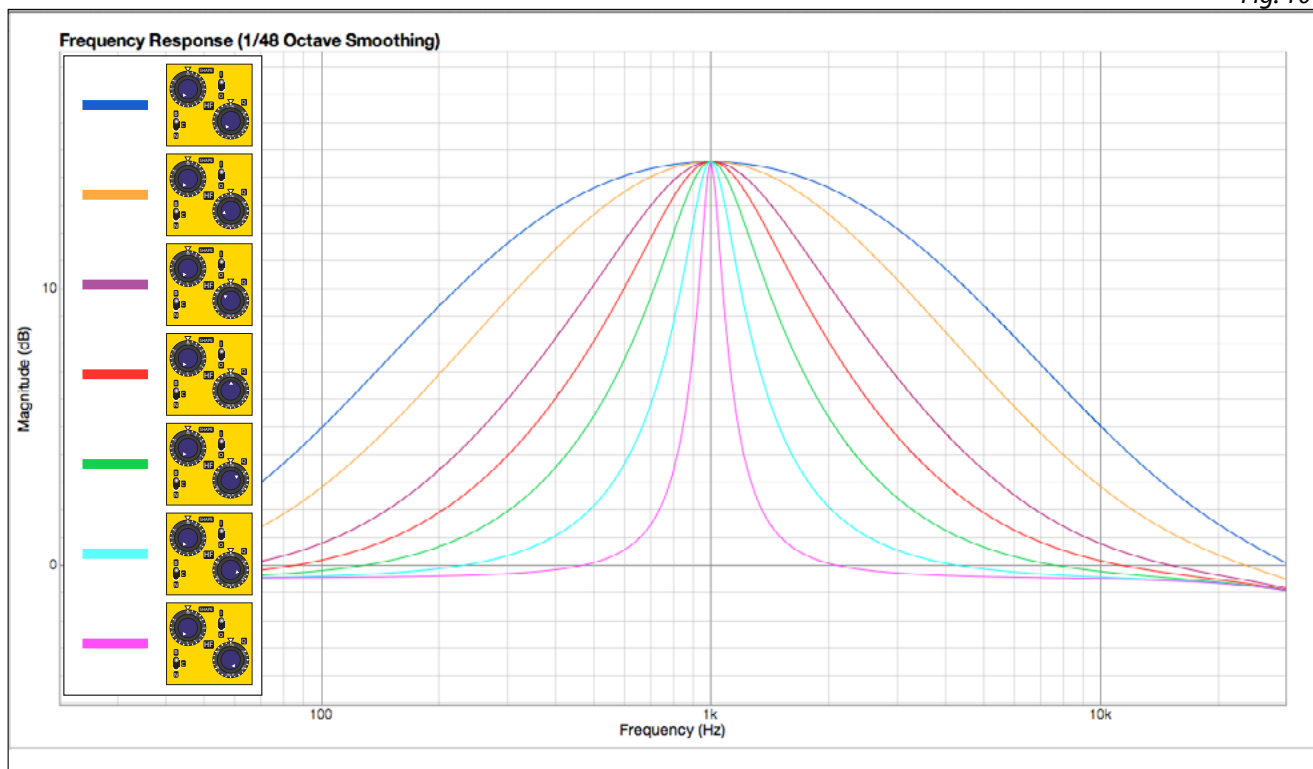

The curves in this graph shows what happens when you have the shape control in the peak (fully counter clock wise position) while turning the Q control clockwise starting from the fully counter-clockwise position. The lowest setting achieves a very wide Q of about .3. The highest setting or fully clockwise position achieves a very narrow Q of about 10.

The wider settings are good for making overall tonal changes to a sound. You can boost or cut a broad section of frequencies to make a sound generally brighter or "bassier". The more narrow settings are excellent for addressing a specific frequency. If there is an offending overtone in a guitar track, you can surgically remove it without changing the overall tonal balance of the sound.

SERIES VS. PARALLEL

There are two main ways the filters in an equalizer circuit will interact - either a series type interaction or a parallel type interaction. When using multiple bands of an equalizer, the different interactions can be dramatic. Here is a list showing the interactive behavior of some familiar equalizers we measured.

SERIES SSL (all versions) Neve 88R Orban 672 API 550A API 560	BOTH UTA NTI EQ3	PARALLEL GML Quad 8 Helios-ish
---	-----------------------------------	--

Fig. 11

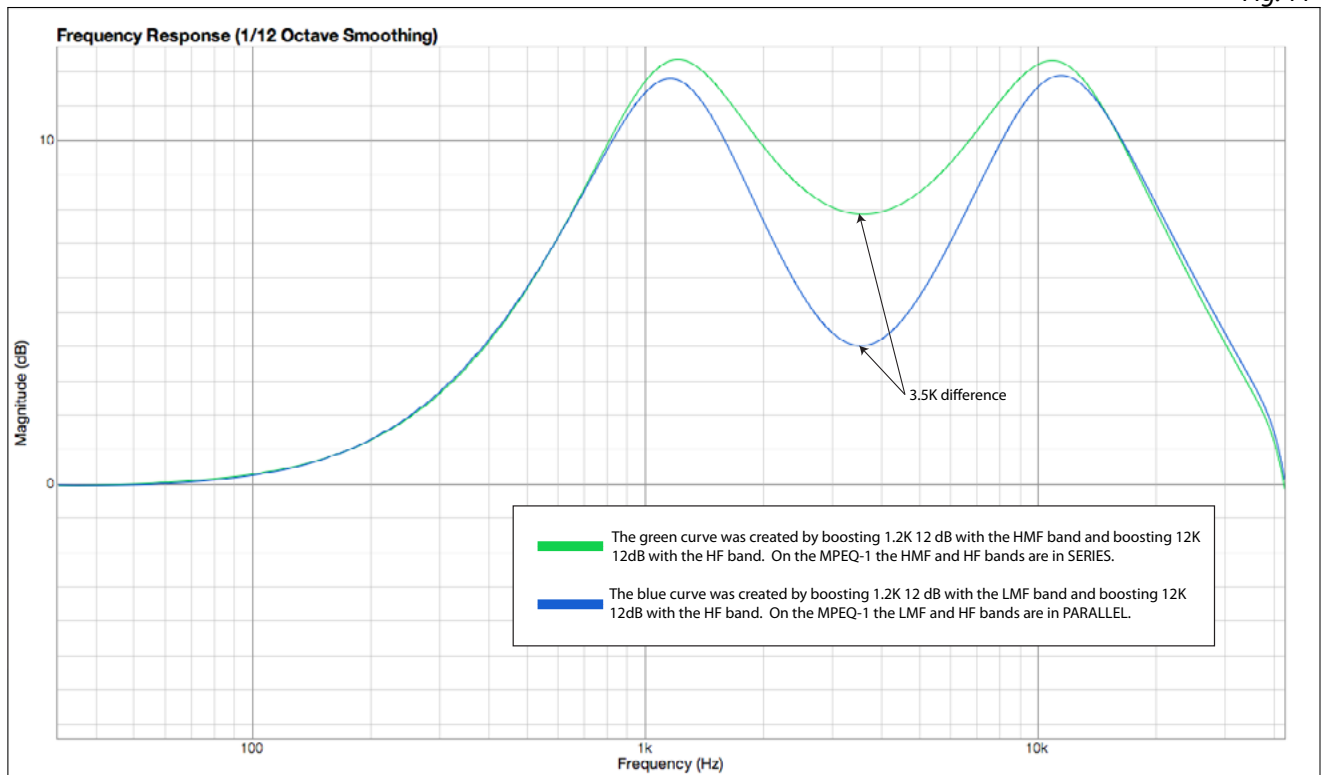

You can see the dramatic difference in how the two separate boosts add up in the area where they overlap. At 3.5 kHz, there is a 4 dB difference in the resulting curves and, as you could imagine, they sound very different. The difference is caused by a difference in the phasing at the intersecting points in the curves. The series interaction can be described as being more "literal" because the two individual boosts will add to each other where they overlap. The parallel interaction can be described as being more "natural" because if you had a room that was acoustically causing these exact two individual boosts (12 dB at 1.2 kHz + 12 dB at 12kHz), the resulting curve would look like the parallel version.

The illustrations in Fig. 12 show which bands of the equalizer interact in parallel and which ones interact in series. You can choose to have a parallel or series interaction based on which pair of bands you choose to use. For example, let's say you want to boost 200 Hz with the LMF and you also want to boost 6K as well. If you boost 6K with the HMF band, it will be a series interaction. If you boost 6K with the HF band, it will be a Parallel interaction.

Fig. 12

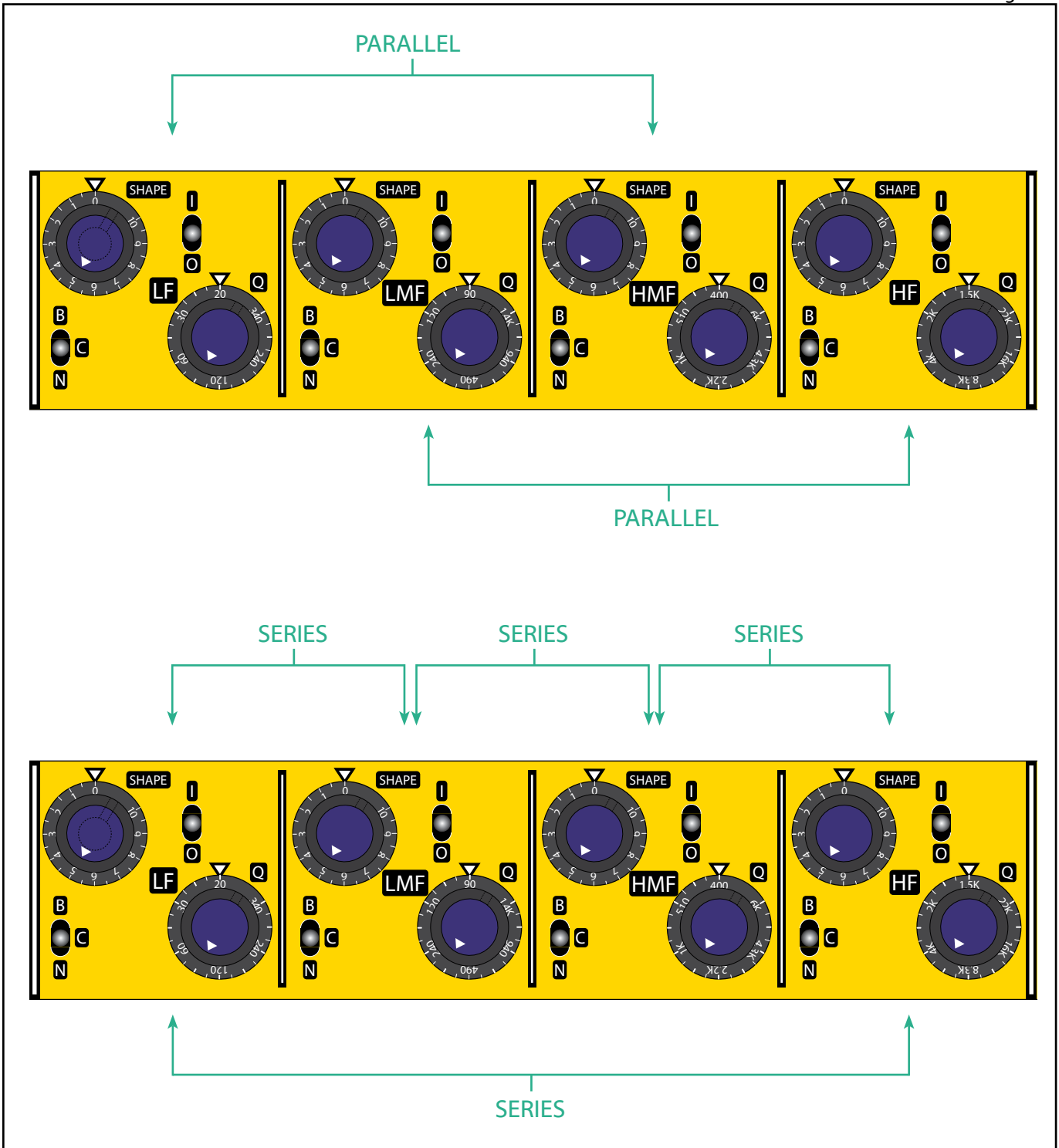

NOTCH MODE

There are 2 functions made available by the Notch Mode: Notch Filtering and Phase Adjust.

1) NOTCH FILTERING

First we will look at the Notch filtering. The Notch filtering works similarly to the Cut mode. The EQ circuit is simply filtering the signal, reversing its phase, then blending it back in with the original signal. When the phase reversed filtered signal is blended back in with the original, it will start to cancel those frequencies isolated by the filter. The "cut" mode is set up such that it will only cancel the selected frequency by a maximum of 15 dB. In Notch mode, the gain structure is adjusted to allow you to completely cancel out the selected frequency. This cancelling out of the selected frequency occurs when the gain control is set to "5".

Fig. 13

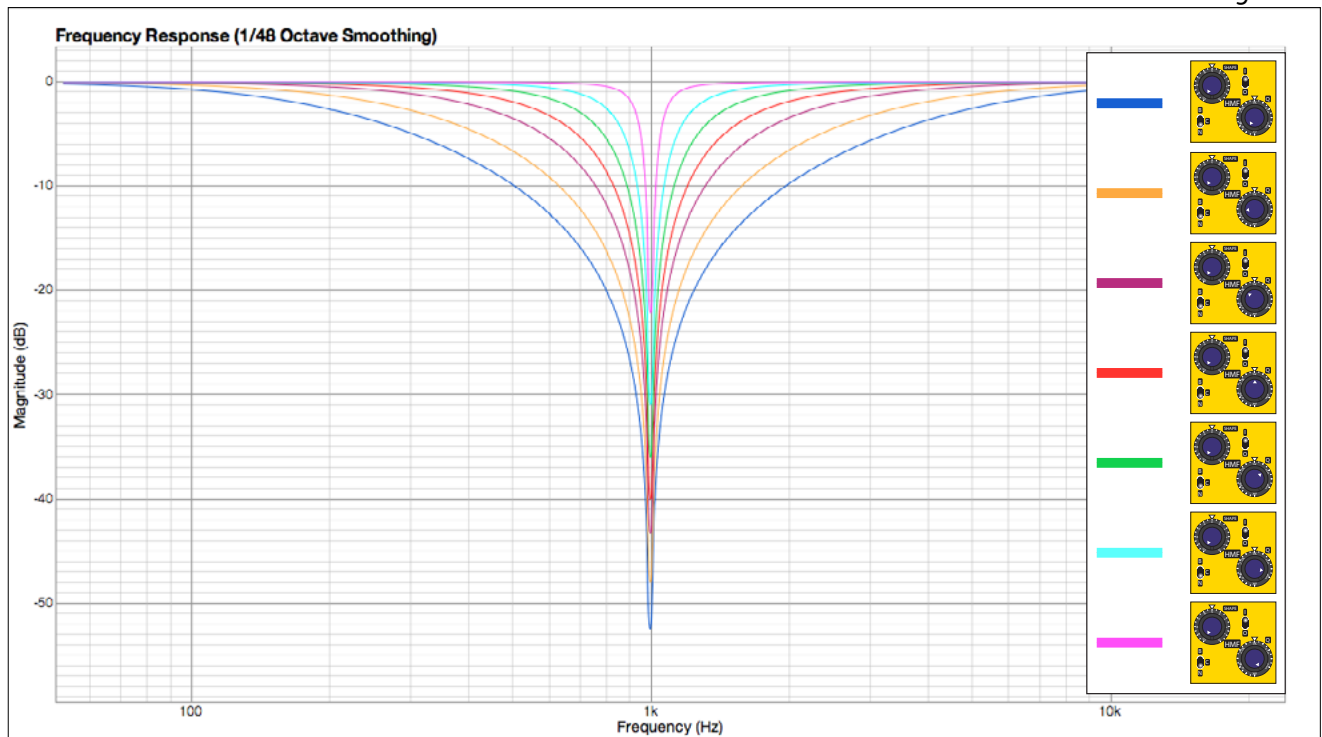

As you can see in *fig. 13*, the Notch Mode allows you to achieve an enormous amount of cut. Our test equipment is measuring over 50 dB of reduction at the selected frequency. With the Q control you can adjust how wide the notch is. In theory, the amount of cut stays the same as the Q gets narrower, but the graphs do not have the resolution to show this. Notch filtering is very useful for eliminating an offending frequency. You can use it to remove a 60 Hz hum or the hi whining sound of a computer fan or disk drive.

The shape control also stays active while in Notch Mode. With the shape control in the 12 o'clock position, the Notch Mode will make parametric bands function like HP/LP filters. The LF and LMF bands will turn into HP (High Pass) filters. The HMF and HF bands will turn into LP (Low Pass) filters. This can allow you to do some more extreme filter effects.

2) PHASE ADJUST

The Phase Adjust function is achieved by turning the gain control to "10" (fully clockwise) while the EQ band mode switch is in the "N" or "Notch" position. Both the "Shape" and "Q" controls stay active and hugely influence the how the Phase Adjust will perform.

The Phase Adjust mode is an extension of the Notch Filter mode. The same filtered, phase reversed signal is being turned up past the null point so it will start to blend back in with the original signal. When the gain control is at the “10” or fully clockwise position the filtered, phase reversed signal is then at unity gain with the original signal. What you have done at that point, is reversed the phase of a portion of the frequency spectrum. With the right shape/Q settings, it can be done without changing the frequency response of the original sound at all.

Fig. 14

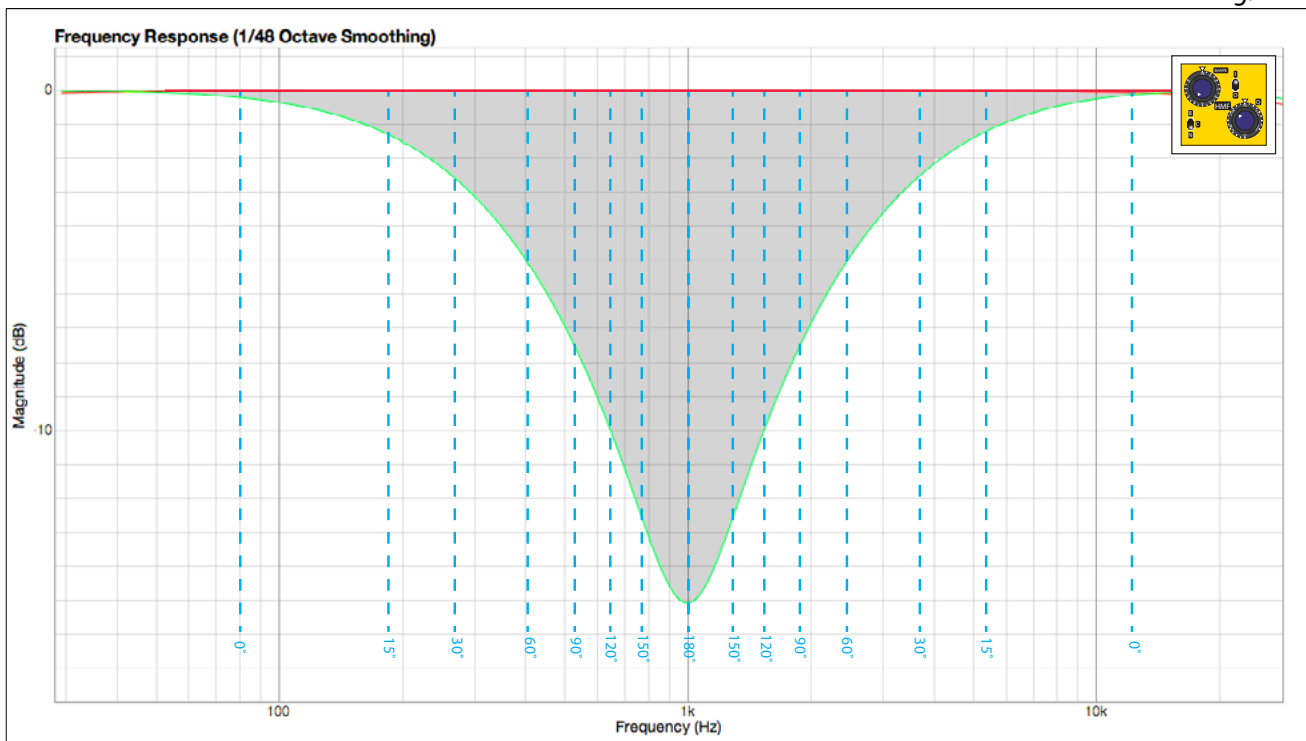

The graph in *fig. 14* is optimized to illustrate what is happening and is not intended to be a technical representation of the function. The red line across the top is showing the actual frequency response of the processed signal. You can see that it is pretty flat across meaning that when soloed, it does not sound any different. The green line is showing the width of the phase adjustment being made. The greyed area is showing the portion of frequencies that are being affected by the phase adjustment. The dashed light blue lines are showing the degree of phase shift as you travel away from the selected frequency in both directions.

With this example, all of the information in the original sound at the 1 kHz frequency has been phase reversed 180°. The degree of phase shift then starts to travel back to 0° as you move away from the 1 kHz frequency range. For example, above you can see that there is a 90° phase shift both below the 1 kHz selected frequency (at about 530 Hz) and above (at about 1.9 kHz). This is how you can achieve varying degrees of phase shift in a specific frequency range.

Why would you want to do this? Well, we initially weren't really sure. Larry had realized that this was possible with the unique approach to subtractive EQ we were using. Because this feature had never really existed before, neither of us really had any idea how useful it might actually be. As it turns out, not only can it be useful, it can actually be a lifesaver!

I have mostly been using the feature on drums, bass, and guitars. These are instruments that will frequently have multiple signals capturing a single sound source. With drums, whenever you use more than one microphone on the kit, there is a phase interaction that can dramatically affect the overall sound. If you are blending multiple amps or microphones for a guitar sound, the phase interactions hugely influence the blended sound. It is common to use both an amp and DI signal for electric bass and again, the phase interactions become very important.

With drums, I have been able to correct phasing problems that resulted from poor mic placement. Sometimes a mic will be placed such that it is 90° out of phase with other mics it is blending with. A traditional 180° phase switch can not correct this problem and it will usually require excessive EQ'ing to make up for the loss of body when the signals are blended. With the Phase Adjust feature you can incur a 90° phase shift within the necessary frequency range to correct the problem and preserve a more natural sounding blend of the microphones. There is a more detailed example of this here <http://under-toneaudio.com/eq.html>.

On bass, I have had situations where the amp and DI signals don't quite blend together in an optimum way. The 2 sources will either sound punchy but too nasally or deep but not punchy enough. With the deeper version, I can phase reverse a portion of a slightly higher frequency range (around 150 Hz) to get some more punch while having enough control to make sure it doesn't get nasally sounding. This fix can happen without either of the signals being EQed or sounding any different than they originally did. I am only changing how the signals are blended together to achieve the results I want.

On guitars it can be really cool. I like to use multiple amps and will sometimes use the variable phase feature to fix a problem. Other times, I will use it to intentionally cause the different amps to blend in weird ways to get a unique tonality that will really stand out in a mix or from other guitars. When these tonal changes are done by manipulating the phase, the results always seem to be more natural sounding. They don't sound like I forced them there with EQ.

IMPORTANT INFORMATION ABOUT THE SETTINGS!!!

There are 3 settings that will give the best results for adjusting phase. When I use the phase adjust feature, I want it to only affect the phase and not change the frequencies or sound EQed at all. There do exist settings that will sound EQed, so read up!

SETTING NUMBER 1

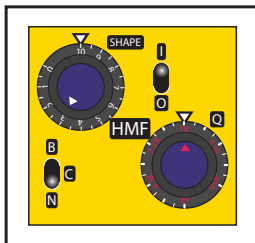

Setting 1 will give you a bell shaped phase reversal (see *fig. 13*) where the selected frequency is reversed 180° and then the degree of phase shift will travel back to 0° in both directions. You can change both the frequency and the Q (highlighted in red) as much as you want without changing the frequency response. The shape control must stay in the fully counterclockwise position and the gain control must stay in the fully clockwise (and a gain setting of "10") position or the frequency response will not remain flat.

SETTING NUMBER 2

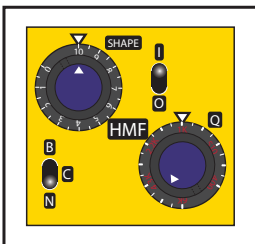

Setting 2 will give you a shelf shaped phase reversal. If you are using either the LF or LMF bands, the 180° phase shift at the selected frequency will extend through the frequency range below that point. If you are using either the HF or HMF bands, the 180° phase shift at the selected frequency will extend through the frequency range above that point. To maintain a flat frequency response in this setting, the gain control must stay at 10, the Shape control must stay at 12 o'clock, and the Q control must stay in the fully counter-clockwise position. You can freely change the selected frequency (highlighted in red) without affecting the frequency response.

SETTING NUMBER 3

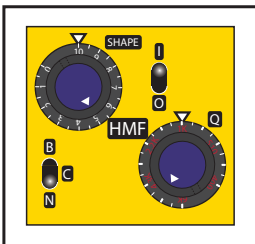

Setting 3 will also give you a shelf shaped phase reversal except it will be a 0° phase shift at the frequency selected and will travel towards 180° beyond that point. This setting is good for causing a phase shift at the extreme ends of the frequency spectrum. To maintain a flat frequency response in this setting, the gain control must stay at 10, the Shape control must stay fully clockwise, and the Q control must stay in the fully counter-clockwise position. You can freely change the selected frequency (highlighted in red) without affecting the frequency response.

7. PRESETS

In this section, we will give you examples of settings that will emulate the curves and shapes that are created by some of the popular classic analog equalizers. Hopefully, this guide will allow you to quickly get to some familiar results.

First, I would like to talk a little bit about how I derived the settings and what you can expect from the presets. The information on the rest of this page is not really essential. Feel free to skip it and go directly to the presets if you like.

I used software called Fuzz Measure to graph the frequency response of all the various equalizers I tested. To replicate a particular curve, I would make sure the levels were matched when no EQing was being done and then match up a particular setting. It would take about 10-15 rounds of refining the settings to get the frequency response of the MPEQ-1 to exactly match the curve of the device being copied. I would then photograph the MPEQ-1 setting and replicate it graphically for this manual.

On devices that are somewhat similar technology (solid state discrete), the results really sound pretty amazingly similar when you get the curves to match exactly. There are however some remaining differences inherent in the different circuits. Things like harmonic coloration and phase shift at the extreme ends of the frequency spectrum are unavoidably going to be different, but they end up being quite subtle. This is because our ears are tuned to be very sensitive to frequency response and volume. Those 2 characteristics will far outweigh the others when trying to replicate the sound of an equalizer.

I ran into some challenges when creating these presets. One was the lack of consistency with much of the vintage gear. For instance, I own four Neve 1064 modules. It turned out that the MPEQ-1 was better able to replicate the high frequency shelf EQ on each of those devices than they were at replicating each other! I was shocked to find out how different they all were. I have used and maintained these Neve 1064s for over two decades and felt like they pretty much sounded the same. But when you are trying to replicate an EQ frequency response curve with a tolerance of .1 dB or better from 20 Hz to 20 kHz, they were certainly not consistent. The Neve 1064/1073 hi EQ shelf preset for the MPEQ-1 replicates an average of the dominant characteristic which is the slope of the hi shelf.

The other challenging issue is the Q or bandwidth behavior of different equalizers. The MPEQ-1 circuit is what many call a "constant Q" type equalizer. Meaning the Q or bandwidth does NOT change when increasing or decreasing the amount of gain. Many vintage equalizers are what people refer to as a "proportional Q" type equalizer. In these circuits, the Q or bandwidth will get narrower as you increase the gain. The presets for these types of equalizers will show a range of adjustment for the Q control on the MPEQ-1. You will have to manually increase the Q as you increase the gain to try and accurately replicate the behavior of the original device.

Finally, there are some devices that are derived from such vastly different technology that the underlying characteristics inherent in their design become more noticable. For instance, I can exactly replicate the curves of my Pultec EQP1A with the MPEQ-1 but the Pultec – with all of its tubes, transformers, and inductors – will have a different personality. Despite this, I still feel it can be useful to know how to recreate these classic frequency response curves.

Controls that are highlighted in **RED** (typically the “SHAPE” and “Q”) must stay in the shown position to maintain the character or slope of the device being replicated. Controls highlighted in **GREEN** (typically the “GAIN” and “FREQUENCY”) can be changed freely as they would be on the device being replicated.

API 550A

SHELF

The 550A Shelf setting was derived by replicating the curve of the 550A when it was set for a 12dB boost at 5 kHz. You can freely change the GAIN and FREQUENCY while maintaining the 550A shelf character. You can see the necessary increase in the “Q” control to maintain the same shape when cutting

BOOSTING

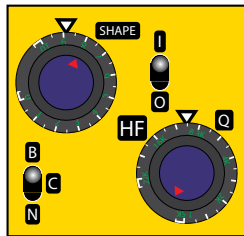

550A 5 kHz shelf +12dB

CUTTING

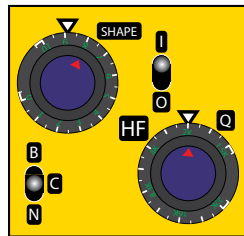

550A 5kHz shelf -12dB

PEAK

The 550A peak or bell curve EQ is a bit trickier because it is a “proportional Q” type. Since the 550A has detented controls, I felt it would be best to show each gain setting. You will see how the “Q” setting on the MPEQ-1 increases (gets narrower) as the gain gets higher. All of the settings were done with the frequency on the 550A set to 800 Hz but these settings will work with any selected frequency on the MPEQ-1.

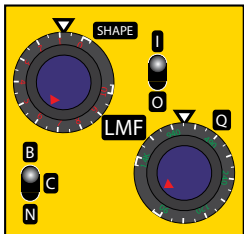

550A 800Hz peak +2dB

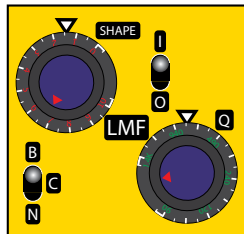

550A 800Hz peak +4dB

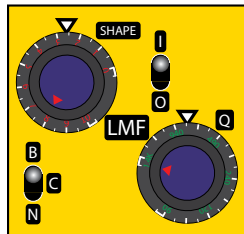

550A 800Hz peak +6dB

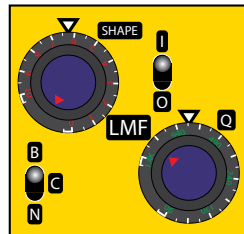

550A 800Hz peak +9dB

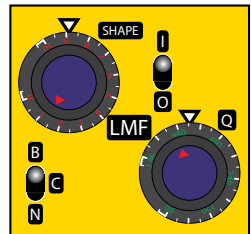

550A 800Hz peak +12dB

HP/LP FILTER

The 550A also has a “FLTR” switch. This engages both a HP and LP filter to the circuit. It can be replicated by setting the HP and LP filters on the MPEQ-1 as shown below.

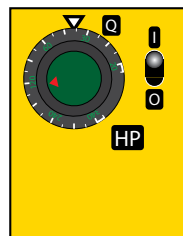

550A HP filter

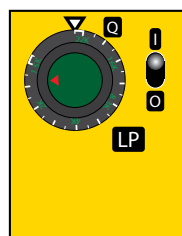

550A LP filter

NEVE 1073/1064

The Neve 1073 is probably the most well known and coveted of the 80 series Neve modules. I tested both an original 1073 and an original 1064. The 1064 is essentially the same circuit as the 1073 but in a larger chassis. They both showed characteristics of having a hi shelf band set to 12 kHz. Both the 1073 and 1064 I tested had the “proportional” type Q behavior for the mid band, meaning the “Q” gets narrower as the gain is increased. Every 80 series module I have ever used has the same peculiar High Frequency roll off when the EQ is engaged. 20 kHz drops 2 dB when the EQ is engaged. I was not able to replicate the HP filter settings because it is an 18 dB/octave filter. The UTA HP is 12 dB/octave with active Q. I just didn’t feel I could get it close enough to include as a preset.

SHELF

The 1073 Shelf settings are pretty straight forward. Simply set the shape control fully clockwise, the “Q” control fully counter clockwise and the frequency about 1/10th of the frequency you want to boost.

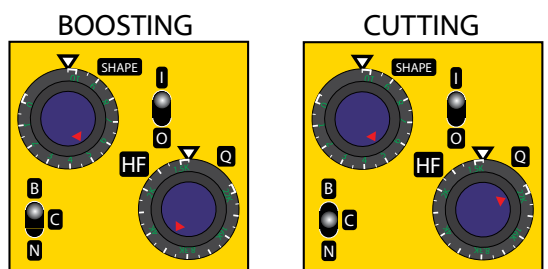

1073 12kHz shelf +15dB

1073 12kHz shelf -15dB

PEAK

The 1073 has a “proportional” type “Q” behavior, meaning the “Q” gets narrower as the gain (boosting or cutting) is increased. Since the 1073 has a constantly variable gain control, I felt it would be best to show a range for the Q setting. I measured the “Q” with 15 dB of boost and with only 2 dB of boost to get an idea of what the highest and lowest “Q” settings would be. You can simply estimate the “Q” setting on the MPEQ-1 based on the amount of boost/cut you are using. For example, if you set the gain control on the MPEQ-1 around 5, then you would set the “Q” control near the middle of the range shown in the graphic below.

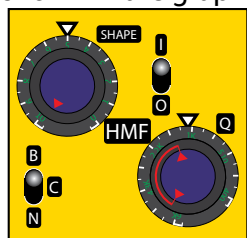

1073 1.2kHz Mid Band

EQ CIRCUIT ROLL OFF

When the EQ circuit on a 1073/1064 is engaged, there is an overall loss of high frequencies. In some cases, it can be an important part of recreating the “warmth” of a vintage 80 series EQ. You can use the LP filter on the MPEQ-1 to get a similar effect.

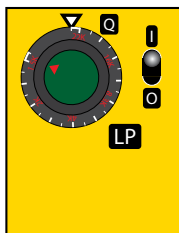

1073 EQ Roll Off

SSL EQUALIZERS

This is the point where you will start to see some repetition in the settings. You'll notice that the SSL "E" settings are very similar to the API 550A shelf setting. In this case the shape of the "CUT" mode on the MPEQ-1 mirrored the "BOOST" mode very closely so you can leave the shape and "Q" settings the same for both.

SSL "E" Shelf

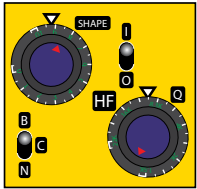

SSL "E" SHELF BOOST

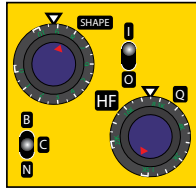

SSL "E" SHELF CUT

The "G" style shelf settings are very similar to the Neve 1073 shelf settings. You'll notice that you will have to increase the "Q" when cutting to achieve an accurate mirror image of the boost curve.

SSL "G" Shelf

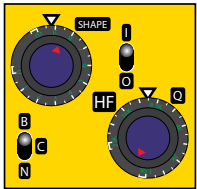

SSL "G" SHELF BOOST

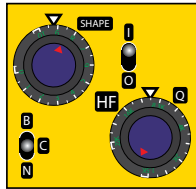

SSL "G" SHELF CUT

SSL Peak Shape

Because the SSL EQ has the same type of controls for the two mid band "peak" EQs, I didn't feel it was necessary to show presets. As you would on an SSL Equalizer, simply listen and set the width of the "Q" for the result you want on the MPEQ-1.

PULTEC EQP1A

The Low Frequency Band is pretty straight forward. I was able to find Shape/Q settings that exactly matched the initial rise or fall when boosting or cutting. The overall bandwidth of the EQP1A is slightly less than the MPEQ-1 so the curves start to diverge a little at the very extreme low end. There is about a 1 dB difference at 10 Hz.

BOOSTING

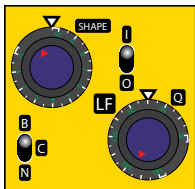

EQP1A 100Hz +15dB

CUTTING

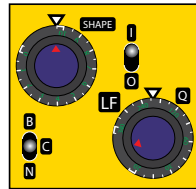

EQP1A 100Hz -15dB

The High Frequency band is a simple peak or bell shape but it is a "proportional Q" type circuit. Both the "Bandwidth" control and the "Gain" interact to determine the actual width of the boost or cut. I measured the EQP1A at both extremes to figure out what the range of "Q" settings would be on MPEQ-1. One measurement was taken at full gain with the Bandwidth at the "0" or sharpest setting. The other measurement was taken at a very low gain setting with the Bandwidth at the "10" or "broadest" setting.

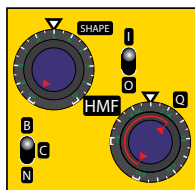

EQP1A 3kHz High Band

8. SPECIFICATIONS

INPUT VOLTAGE110-120/220-240VAC, 60/50 Hz

MAINS FUSE

110V.....T 0.4A
240V.....T 0.2A
MAXIMUM POWER CONSUMPTION.....25W

INPUT IMPEDANCE

MIC IN TRANSFORMERLESS2K ohms
MIC IN 200 Ω2K ohms
MIC IN 50 Ω500 ohms
LINE IN.....Greater than 10K
DI4.7 Mohms

OUTPUT IMPEDANCE

MIC OUT.....47 ohms
MAIN OUT TRANSFORMERLESS47 ohms
MAIN OUT WITH TRANSFORMER120 ohms

FREQUENCY RESPONSE

MIC PREAMP.....10 Hz - 80 kHz +0 /-1 dB
LINE IN/OUT10 Hz - 50 kHz +0 /-1 dB

NOISE FLOOR

MIC PREAMP-128 dBu (20 Hz - 20 kHz)
LINE LEVEL CIRCUIT-91.5 dBu (20 Hz - 20 kHz)

MAX LEVEL BEFORE CLIP

MIC PREAMP+27 dBu (or better)
LINE LEVEL CIRCUIT+27 dBu (or better)

DISTORTION

MIC PREAMP003% at +27 dBu
LINE LEVEL CIRCUIT015% at +27 dBu

DIMENSIONS

FRONT TO BACK 12.25"
(WITH HEAT SINKS and KNOBS)..... 14"
LEFT TO RIGHT 17.25"
(WITH RACK EARS)..... 19"

WEIGHT

ACTUAL10 Pounds
SHIPPING13.4 Pounds

9. USER DOCUMENTS

On the next 4 pages you will find the user documents.

The EQ “WTF” guide is great to print and keep on hand for your self or clients whenever one needs a quick reminder of what the various controls are and how they interact. There is a full color version that includes some additional color coding or if you prefer a simple black and version that is a little easier on your printer cartridges.

We included two versions of the recall sheets. The first one is larger and easier to read but only allows settings for a single MPEQ-1 to be documented on a single 8.5” x 11” piece of paper. The second one allows you to document settings for four MPEQ-1s on a single 8.5” x 11” piece of paper.



UnderToneAudio™

EQ
WTF GUIDE
v 2.0

SHAPE CONTROL:

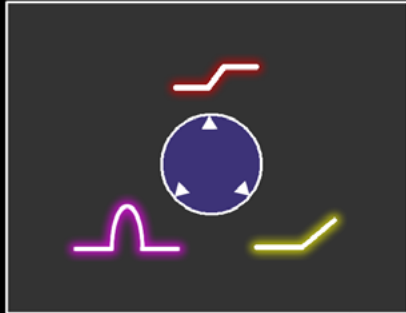

FILTER Q CONTROL:

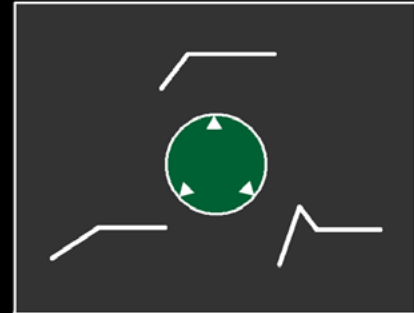

EQ BAND ON/OFF



Q CONTROL:



Q CONTROL:



Q CONTROL:

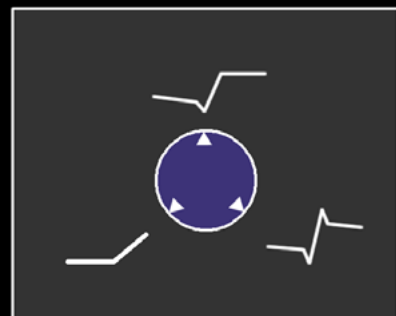
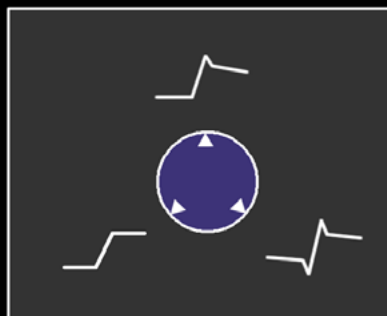
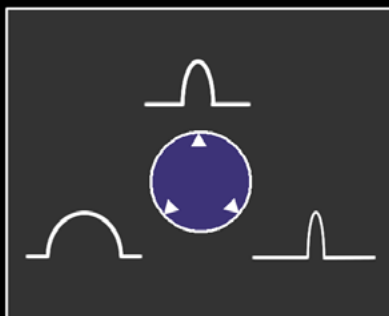
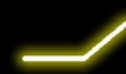



UnderToneAudio™

EQ
WTF GUIDE
v 2.0

SHAPE CONTROL:

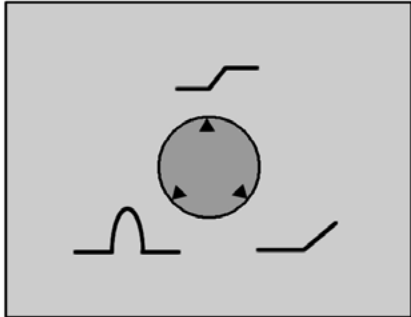

FILTER Q CONTROL:

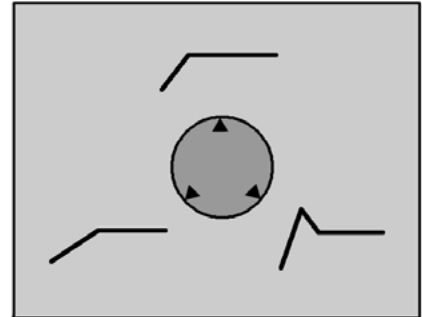

EQ BAND ON/OFF

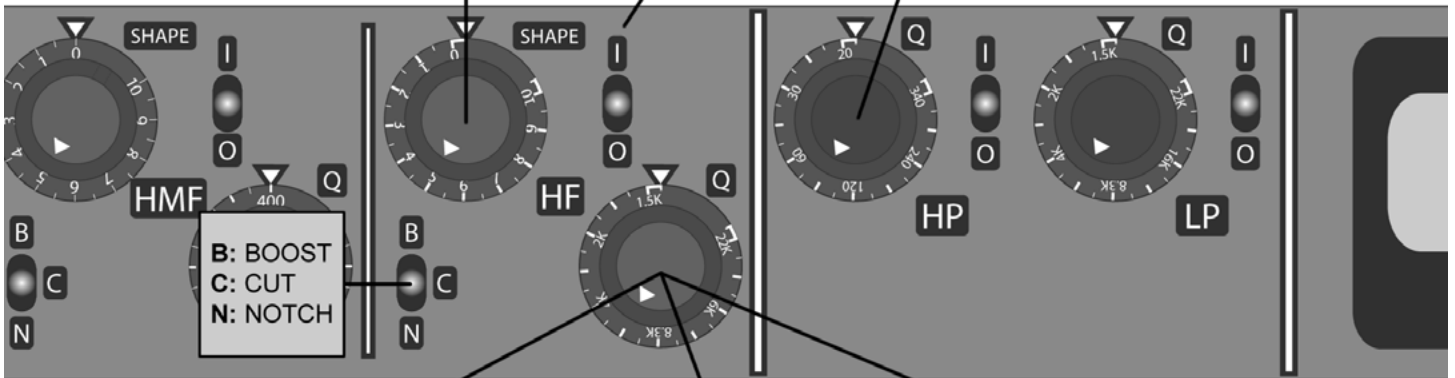

Q CONTROL:

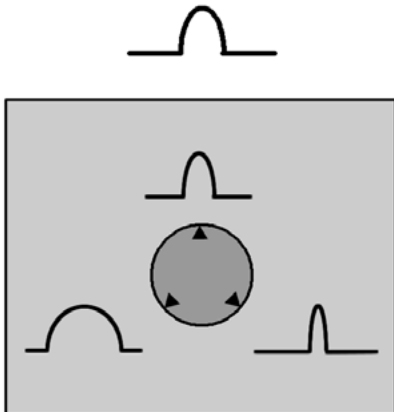

Q CONTROL:

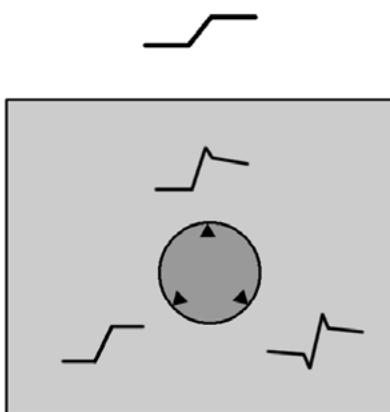

Q CONTROL:

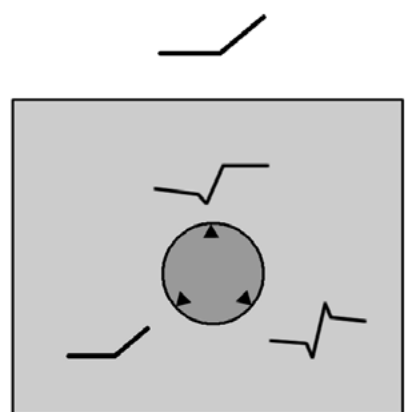

MPEQ-1 RECALL SHEET

USED FOR: _____ DATE: _____

MIC → EQ **PH** **TRIM** **EQ**

SEP **180** **0** **48V** **500Ω** **2000Ω**

-20 **OFF** **Xtrimless**

HP **LP**

OUTPUT

WITH TRANSFORMER

WITHOUT TRANSFORMER

SHAPE **LF** **Q**

SHAPE **LMF** **Q**

SHAPE **HMF** **Q**

SHAPE **HF** **Q**

MPEQ-1 RECALL SHEET

USED FOR: _____

DATE: _____

							OUTPUT WITH TRANSFORMER <input type="checkbox"/> WITHOUT TRANSFORMER <input type="checkbox"/>
--	--	--	--	--	--	--	--

USED FOR: _____

DATE: _____

							OUTPUT WITH TRANSFORMER <input type="checkbox"/> WITHOUT TRANSFORMER <input type="checkbox"/>
--	--	--	--	--	--	--	--

USED FOR: _____

DATE: _____

							OUTPUT WITH TRANSFORMER <input type="checkbox"/> WITHOUT TRANSFORMER <input type="checkbox"/>
--	--	--	--	--	--	--	--

USED FOR: _____

DATE: _____

							OUTPUT WITH TRANSFORMER <input type="checkbox"/> WITHOUT TRANSFORMER <input type="checkbox"/>
--	--	--	--	--	--	--	--